



WERTHEIM

SPINBOT

ROBOT VACUUM & SPIN MOP



SPINBOT

FEATURES

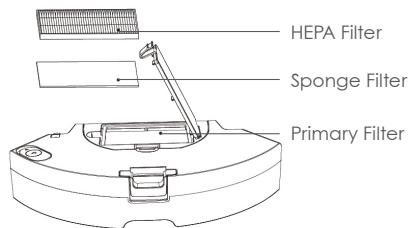
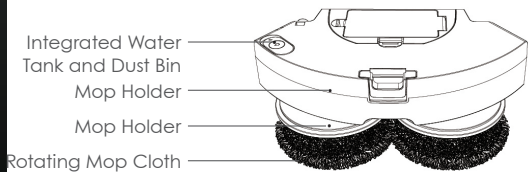
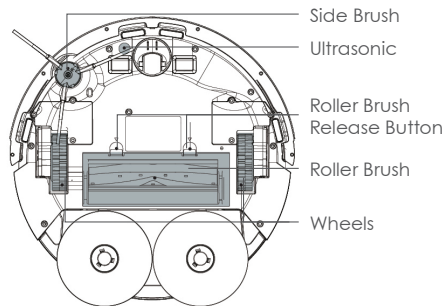
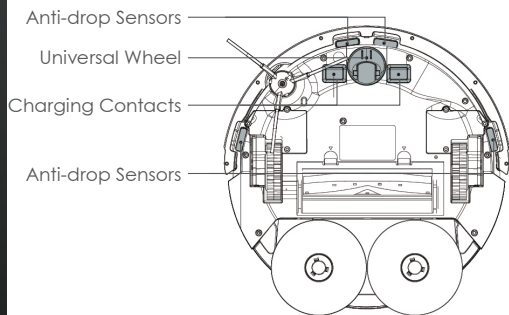
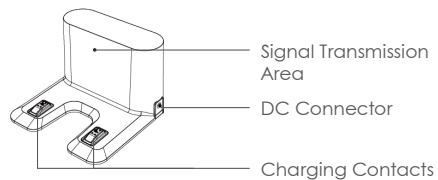
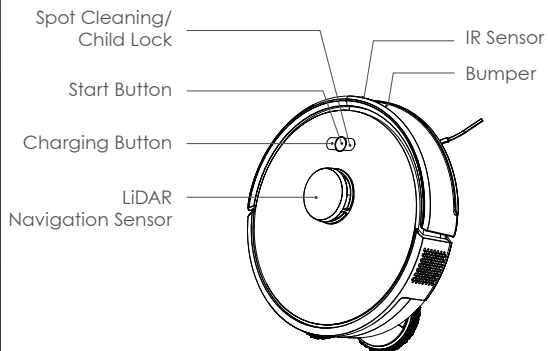

WHAT'S IN THE BOX



Robot Vacuum Cleaner

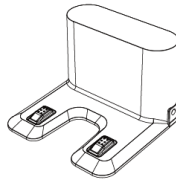

Charging Base

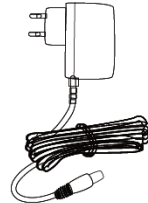

Power Adapter
(connect with charging base)

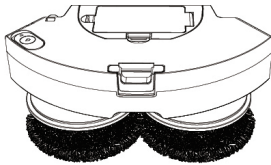

Integrated Water Tank and
Dust Box (with holder and
rotating mop cloth)

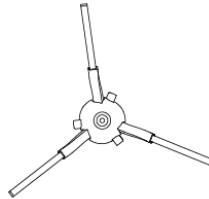

Side Brush



Cleaning Tool

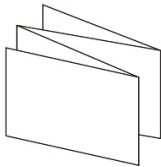

Quick Start Guide

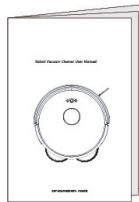

User Manual

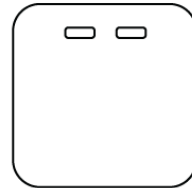

Moisture Barrier Pad

SPINBOT

Please contact Wertheim Customer Service on 131 929 to find your local spare parts provider.



Introduction

Congratulations on the purchase of your new Wertheim SpinBot Robot Vacuum. There are many useful features built into your Cleaner. We recommend that you carefully read this instruction manual to take the best advantage of these features.

Specifications

Battery: 14.4V/4500mAh Li-ion battery
Battery Runtime: 200 min
Charging Time: 4-5 Hours
LiDAR Navigation

Dust Bin Capacity: 150ml
Water Tank Capacity: 250ml
Net Weight: 2.71kg(robot)
Gross Weight: 4.36kg

BEFORE YOU BEGIN

This cleaner must be operated in accordance with these instructions and used only for domestic household cleaning.

This cleaner is not fit to be used as an industrial cleaner and will void the manufacturer's warranty if used inappropriately.

Please read these instructions thoroughly

This will ensure you obtain full benefit from your new cleaner. Keep this instruction manual in a handy place for future reference.

Important

Always switch off the cleaner before cleaning, when not in use, attempting any maintenance task, fitting or removing accessories. The charging base must only be connected to an ac power supply at the voltage shown on the rating label. This cleaner should only be charged with the charger provided. This cleaner should only be used for its intended purpose as described in these instructions.

PRECAUTIONARY MEASURES:



1. **Do not** operate the cleaner too close to heaters, radiators or other hot surfaces.



2. Before inserting the plug into the wall, make sure your hands are dry.



3. Before turning on the cleaner, safely remove any large objects from the floor or cleaning surface in order to prevent damage to the brush roller.



4. When you want to remove the plug from the power socket, **do not** use the power cable, gently pull the plug from the power socket.



5. **Do not** use this vacuum cleaner if the battery pack housing and/or the charger housing is damaged.

SAFETY INSTRUCTIONS



DANGER

**Live Parts
Within**

IMPORTANT! Always switch off the cleaner before cleaning, when not in use or attempting any maintenance task. The charger must only be connected to an AC power supply at the voltage shown on the rating label. This cleaner should only be used for its intended purpose as described in this instruction manual. Never operate the cleaner without filters.

When using your cleaner, basic precautions should always be observed, including the following;

1. This appliance is not intended for use by persons (including children) with reduced physical, sensory, or mental capabilities, or lack of experience and knowledge, unless supervised or instructed by a person responsible for their safety.
2. Children must be supervised at all times to ensure they do not play with the appliance.
3. To prevent electric shock, do not immerse the appliance, battery, or power plug in water or any other liquid.
4. Do not use the vacuum cleaner outdoors or on wet surfaces.
5. Always inspect the power cord and plug before use. Do not use if damaged. If the power cord is defective, it must be replaced by the manufacturer, its service agent, or a qualified technician to avoid hazard.
6. This appliance and its charging base are intended for indoor domestic use only.
7. Do not unplug by pulling on the power cord. Always grasp the plug. Use only electrical extension cords approved for Australia and New Zealand.
8. Do not pull or carry the appliance by the power cord. Do not use the cord as a handle or pull it over sharp edges or corners. Avoid running the appliance over the cord.
9. Do not handle or operate the appliance with wet hands. Always follow electrical safety precautions.
10. Keep the vacuum cleaner away from heaters, radiators, and other hot surfaces.
11. Do not use the appliance to pick up flammable or combustible materials (e.g. gasoline, hot ashes, cigarettes, matches, or burning objects), or in areas where such materials may be present.

12. Do not use the appliance to pick up toxic substances (e.g. chlorine bleach or ammonia).
13. Do not operate the appliance without filters installed.
14. Before use, remove large or sharp objects from the cleaning area to prevent damage to the appliance, filters, or surfaces.
15. If the air inlet becomes blocked, switch off the appliance immediately. Clear the blockage before restarting.
16. Always switch off the appliance before performing maintenance or cleaning the filters.
17. Keep all openings away from your face and body.
18. Do not use the vacuum cleaner if it is damaged or not functioning properly. If any connection cables are damaged, they must be replaced immediately by a qualified technician.
19. Do not clean the vacuum cleaner or any electrical components, including electrical connections, with water or liquid cleaners.
20. Do not attempt to modify the vacuum cleaner or charging base in any way.
21. Store the appliance and charger indoors in a cool, dry place.
22. Use the electric roller brush only for vacuuming dust and dry materials within the home.
23. Do not run the robot cleaner over the power cable, as this may cause damage.
24. Do not touch the roller brush while the appliance is in operation.
25. To prevent unnecessary wear, keep the power head moving during use.
26. Failure to follow these instructions or improper use of the appliance may void the warranty.

Battery use and care

1. This appliance must only be used with the charger supplied with the product.
2. Charge the battery only while it is installed in the appliance, using the designated charger provided.
3. When not in use, keep the appliance away from metal objects such as paper clips, coins, keys, nails, or screws. Contact between terminals may cause a short circuit, resulting in burns or fire.
4. Under extreme conditions, battery liquid may leak. Avoid contact. If contact occurs, rinse immediately with water. If liquid comes into contact with eyes, seek medical attention. Battery liquid may cause irritation or burns.
5. Do not charge or store the appliance outdoors or inside a vehicle. Charge and store the appliance in a dry indoor environment with a

temperature between 5°C and 45°C. The charger is for indoor use only.

6. Do not attempt to open or disassemble the battery. If the battery casing is damaged or cracked, discontinue use immediately and do not recharge.
7. The charger adapter contains internal electrical components and is not serviceable.
8. Before disposing of the battery, fully discharge it by running the appliance until it stops.
9. This appliance contains a lithium battery. Do not dispose of it with household waste. Contact your local council for safe disposal instructions.
10. Do not use the charger to charge non-rechargeable batteries.
11. Do not touch or insert objects into the battery terminals.
12. Do not short-circuit the battery terminals.
13. This appliance contains non-replaceable battery cells.

Risk of Damage

1. Lightweight or movable objects may be dragged by the robot vacuum, potentially causing damage to the object or floor surface.
2. Remove any loose or lightweight items from the cleaning area before use.
3. Secure any exposed or hanging cables (e.g. from floor lamps) to prevent entanglement or damage.

Risk of Fire

1. Do not operate the robot vacuum near heaters, radiators, or other hot surfaces.
2. Do not spray or pick up flammable liquids, cleaning agents, aerosols, or their vapours, as this may increase the risk of fire or explosion.
3. Do not use the robot vacuum to pick up burning or glowing materials, such as embers or cigarette butts.
4. Do not expose the battery to open flames or external heat sources.

Laser Navigation Sensor

1. This appliance contains a Class 1 rotating laser sensor for navigation.
2. The following safety precautions must be observed:
 - Switch off the robot vacuum before performing any maintenance or adjustments.
 - Do not aim the laser beam at people.
 - Do not look directly at the laser beam or its reflections.
3. Modifications or repair attempts to the device, particularly the navigation sensor, are strictly prohibited.

ASSEMBLY

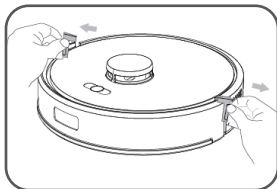

1. Before first use, remove all protective strips and films from both the robot and the charging base.

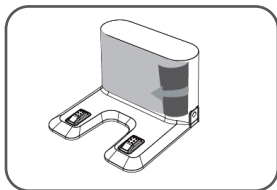

2. Remove the protective film

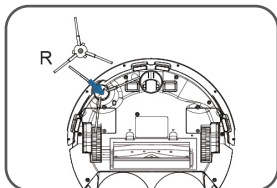

3. Install the side brushes securely onto the robot.

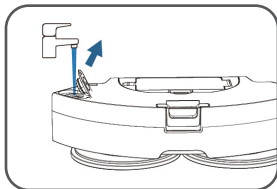

Install Water Tank & Dust Bin

1. Open the cover and fill the water tank with clean water. Ensure the water level is appropriate before closing the lid.



Warning: Do not add detergent, chemicals, bleach, eucalyptus oil, or any other substances to the Water Tank. Use clean water only. Adding any other substances may damage the Water Tank and internal components, and will void the warranty.

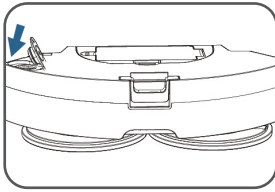

2. Close the water inlet cover securely, making sure it is fully sealed with no raised edges to prevent leakage.

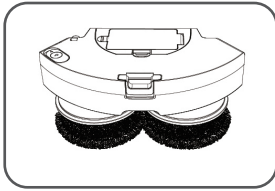

3. Attach the spin mop holder and secure the spin mop cloth firmly in place. Ensure it is aligned properly before use.

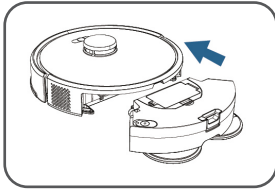

4. Press and hold the release button, then insert the integrated water tank and dust bin into the robot until it clicks into place.

Important Tips:

1. Use purified or soft water to extend product life
2. Do not use the mopping function on carpets
3. Empty the water tank and remove the mop holder after use
4. With mop installed: vacuum and mop simultaneously (suction defaults to low)
5. Without mop: vacuum-only mode
6. A small amount of water residue may remain due to factory testing

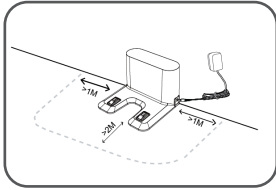

Charging the Robot

1. Place the charging base on a flat surface against a wall. Ensure there are no obstacles, stairs, or drop-offs within:
 - 1 metre on both sides
 - 2 metres in front
2. Connect the charging base to the power supply.
3. Position the robot onto the charging base, ensuring the charging contacts align correctly. The robot will announce "Charging" and begin charging automatically.
4. During charging, the Start button will flash with a white breathing light. Once fully charged, the light will remain solid white.

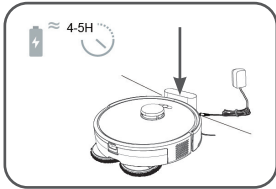

Important Notes

1. During daily use, always keep the robot on the charging base and ensure the base is connected to power.
2. Regularly clean the charging contacts to maintain optimal charging performance.
3. If the robot will not be used for an extended period, fully charge it, switch it off, and store it in a dry, ventilated area.
4. If the battery has been unused for a long time or becomes over-discharged, it may not charge properly. Contact customer service for assistance. Do not attempt to disassemble the unit.



Additional Tips

1. Keep reflective surfaces (e.g. mirrors or glass) away from the charging base.
2. Avoid placing the charging base in direct sunlight.
3. For first-time use, fully charge the robot before operation.
4. Typical charging time is approximately 4–5 hours.

PRECAUTIONS

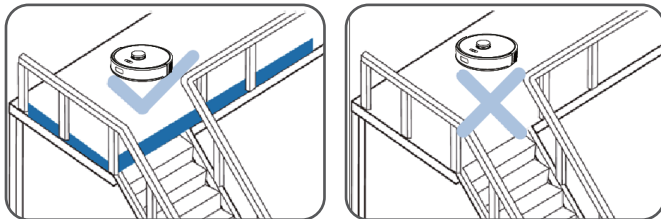

1. **Ensure safe operation near edges**

When cleaning near stairs or edges, observe the robot to ensure safe operation

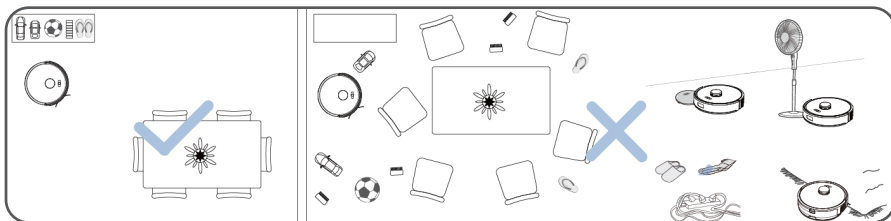

1. **Remove obstacles and entanglement hazards**

Clear all objects that may obstruct or entangle the robot, such as power cords, ropes, or loose items. High steps or uneven surfaces may cause the robot to become stuck.

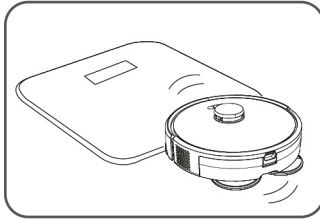
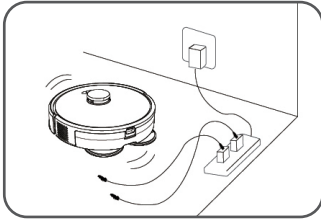

1. **Prepare the cleaning area**

Arrange furniture and remove obstacles in advance to ensure smooth operation. Low-profile objects (e.g. weighing scales or fan bases) should be removed or covered to avoid interference.

2. **First-time use and surface preparation**

For first-time use, monitor the robot during operation to identify potential issues and ensure efficient cleaning. Avoid standing directly in front of the robot while it is moving. Tuck in carpet edges or tassels to prevent entanglement.

INSTRUCTIONS FOR USE

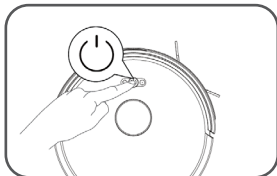

1. **START Button**

- Power On/Off: Long press for 3 seconds to power the robot on or off.
- Start / Pause: Short press to start cleaning. Short press again to pause.
- Wake Up: If the robot has been paused for more than 4 hours, the indicator light will turn off. Long press to wake the robot up.

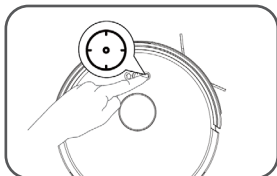

2. **SPOT CLEANING Button**

- Spot Clean: Short press to clean a 1.5m × 1.5m area centred around the robot's current position.
- Child Lock: Long press for 3 seconds to activate or deactivate Child Lock. When enabled, all physical buttons and smart speaker controls are disabled. The robot can still be controlled via the App.

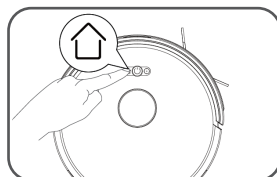

3. **CHARGING Button**

- Return to Charge: Short press to send the robot back to the Charging Base.
- Reset: Long press to reset the robot.

APP SETUP & FEATURES



Connect to the APP

- 1. Download the App**
Scan the QR code on the Charging Base to download and install the VacConnect App, or search for it directly in the App Store (iOS) or Google Play Store (Android).
- 2. Create an Account**
Open the HOME App and create a new account, or log in if you already have one.
- 3. Add the robot cleaner**
Go to My Device, tap "+" in the upper right corner, then follow the in-app instructions to add your robot cleaner.
- 4. Enter Configuration Mode**
If the robot cleaner does not connect, press and hold the Charging Button and Spot Cleaning Button together for 3 seconds until you hear a voice prompt, then follow the in-app steps to complete setup.



Important Notes

1. App requires iOS 13.0 or above, or Android 6.0 or above.
2. Ensure your smartphone is connected to your home network before setup.
3. The SpinBot supports 2.4 GHz Wi-Fi only. Select the 2.4 GHz network during setup.
4. If no Wi-Fi is available, use your smartphone's Personal Hotspot to connect the SpinBot.

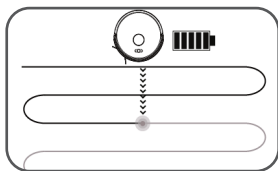

Breakpoint Resume

If the battery runs low during cleaning, the SpinBot will automatically return to the Charging Base to recharge, then continue cleaning from where it left off.

Note: The SpinBot will not resume cleaning if Do Not Disturb mode is active, or if it was manually moved or recharged.

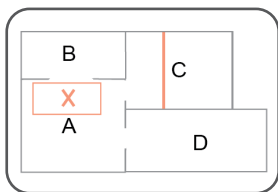

Restricted Area

Set No-Go Zones, No-Mop Zones, or virtual walls on the map to prevent the SpinBot from entering certain areas. No-Mop Zones are only active when the Mop Holder is installed.

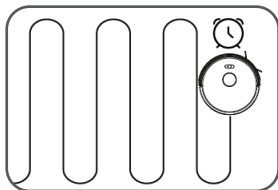

Scheduled Cleaning

Set a cleaning schedule in the App. The SpinBot will clean automatically at the set time and return to the Charging Base when finished.

Note: Scheduled cleaning will not run if the SpinBot is in low battery or Do Not Disturb mode.

More Functions

The VacConnect App also includes: Real-Time Map View, Cleaning Mode Settings, Maintenance Schedule, Cleaning History, Remote Mode, Robot Status, Remaining Power, Positioning Robot, Firmware Updates, Voice Settings, and Do Not Disturb (DND) Mode.

MAINTENANCE

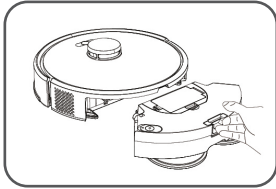

Cleaning Water Tank & Dust Bin

1. Press and hold the release key and pull out the Integrated Water Tank & Dust Bin.

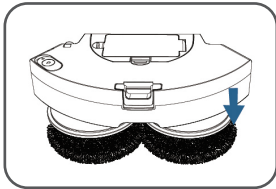

2. Remove the Mop Holder and Mop Cloth.

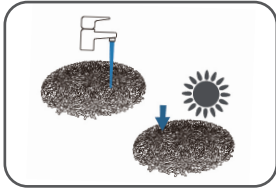

3. Wash and air-dry the Mop Cloth.

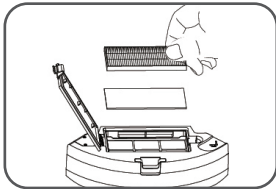

4. Open the dust bin and remove the Primary Filter, HEPA Filter, and Filter Sponge.

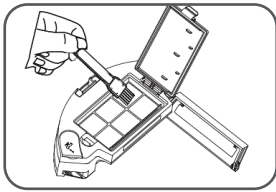

5. Clean the Primary Filter with the cleaning tool brush. Tap the HEPA Filter to remove dust.

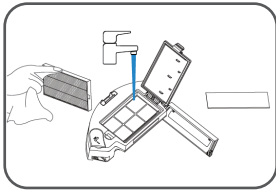

6. Wash the dust bin and Filter Sponge with water. Do not wash the HEPA Filter — if it gets wet, air-dry it before use.

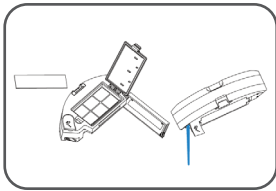

7. Empty and air-dry the Water Tank, dust bin, and Filter Sponge in shade before storing.

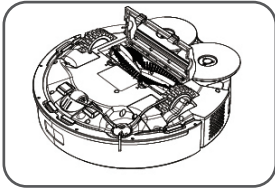

Cleaning Roller Brush & Side Brush

1. Pull the release tabs to unlock the brush guard.

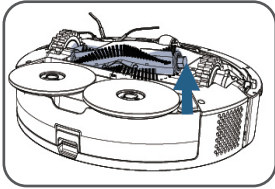

2. Lift out the Roller Brush.

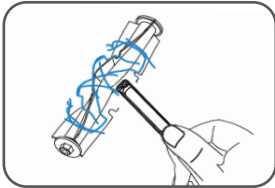

3. Clean the Roller Brush with the cleaning tool brush.

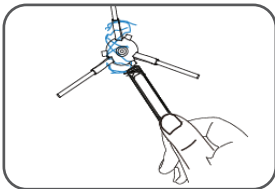

4. Clean the Side Brush with the cleaning tool brush.

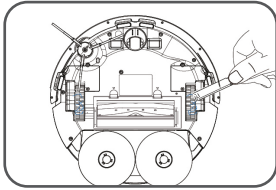

Cleaning Driving Wheel & Universal Wheel

1. Use the cleaning tool brush to remove hair and debris from the Driving Wheel.

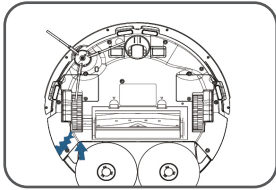

2. If the Driving Wheel is stuck, flip its gear in the opposite direction to release any trapped debris.

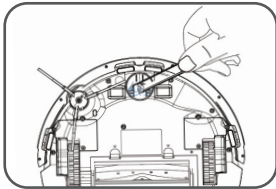

3. Use the cleaning tool brush to remove hair and debris from the Universal Wheel.

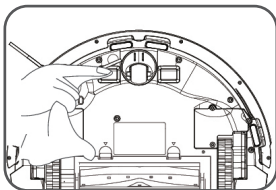

Cleaning Charging Contacts

1. Wipe the Charging Contacts on the SpinBot with a dry cloth.

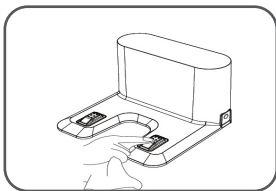

2. Wipe the Charging Contacts on the Charging Base with a dry cloth.

Warning: Always use a dry cloth only — moisture can damage the Charging Contacts.

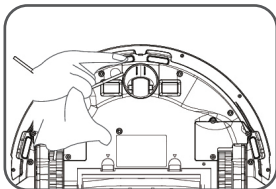

Cleaning Anti-Drop Sensors & Bumper

1. Wipe the Anti-Drop Sensors with a dry cloth.

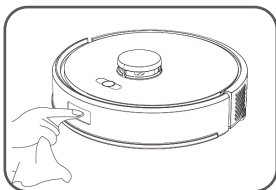

2. Wipe the IR Sensor with a dry cloth.

Warning: Always use a dry cloth only — moisture can damage these components.

TROUBLESHOOTING

Problems and Solutions

Please contact Godfreys Commercial Customer Support on 131 929 to find your local spare parts provider.

Issue	Possible Cause	Solutions
Robot cannot power on	Battery is depleted	Charge the robot before use.
	Ambient temperature is outside the operating range	Use the robot in an environment between 0 °C and 40 °C.
Robot fails to start cleaning	Battery is depleted, or the side brush, roller brush, dust box, or filter are clogged or tangled	Charge the robot. Check for any error alerts. It is recommended to regularly clean and maintain the side brush, roller brush, dust box, and filter.
Reduced cleaning performance	The dust box is full	Empty and clean the dust box.
	The filter is clogged	Remove and clean the filter.
	The roller brush is entangled with hair or objects	Remove and clean the roller brush. Refer to the Regular Care & Maintenance section for instructions.
Robot is unable to charge	The charging base is not connected to the power supply	Ensure the charging base is plugged in and that its indicator light is on.

Issue	Possible Cause	Solutions
	The robot's charging contacts are not properly connected to the charging base charging contacts, or the contacts are dirty	Seat the robot securely on the charging base and confirm the START button is flashing. If the contacts appear dirty, clean them as described in the Regular Care & Maintenance section of this manual.
	Ambient temperature is outside the charging range	Charge the robot in an environment between 0 °C and 40 °C.
	The battery has been deeply discharged due to an extended period without use	It is recommended to use the robot regularly. If prolonged storage has resulted in a charging issue, please contact after-sales service for assistance.
Unable to install the App	The mobile operating system version is too old	The App requires iOS 13.0 or later, or Android 6.0 or later. Please update your device's operating system and try again.
Robot cannot connect to the App	The router username or password is incorrect	Reconfigure the router settings and ensure the correct username and password are entered.
	The robot is outside the router's Wi-Fi coverage area	Move the robot closer to the router to ensure it is within the network signal range.

Issue	Possible Cause	Solutions
	The robot is not in configuration (pairing) mode	Ensure the robot is connected to power and switched on. Press the Charging Button and Spot Cleaning Button simultaneously for 3 seconds. The robot will announce a voice prompt to confirm it has entered configuration mode.
	The router is broadcasting on a 5 GHz network only	The robot only supports 2.4 GHz Wi-Fi. Please switch your connection to a 2.4 GHz or dual-band 2.4/5 GHz network.
	The wrong App has been downloaded	Scan the QR code on the charging base, or download the HOME App directly from your device's app store.
Navigation errors during cleaning (e.g. disordered route, deviation, repeated cleaning, or small areas left uncleaned)	Scattered objects on the floor (cables, slippers, etc.) are disrupting the robot's path	Clear the floor of loose items before starting the robot. If any area is missed, the robot will return to clean it automatically — please do not interfere by moving the robot or blocking its route.

Issue	Possible Cause	Solutions
	The robot's driving wheels lost traction when crossing a step, threshold, or door strip, causing it to misread the overall floor plan	Close the door to the affected area and clean it separately. The robot will return to its starting point once it has finished that zone.
	Operating on a newly waxed, polished, or very smooth tile floor reduces traction between the driving wheels and the surface	Allow the floor wax or polish to dry completely before using the robot.
	The distance sensor is dirty or obstructed	Clean the distance sensor and remove any objects covering it.
	Due to the home layout, the robot cannot access certain areas	Rearrange the home environment where possible to allow the robot to enter and clean those areas.
Robot reverses or backs away	There is an obstacle ahead	Clear the path in front of the robot.
	The front bumper is stuck	Tap the bumper gently to check whether something is caught in it.
	The anti-drop sensor lens is dirty	Clean the surface of the anti-drop sensor lens.
Robot becomes stuck during operation	The robot is tangled or obstructed by loose cables, drooping curtain fabric, or carpet fringe on the floor	The robot will attempt to free itself automatically. If it cannot, manually clear the obstacle and restart the robot.

Issue	Possible Cause	Solutions
	The robot is wedged under furniture with a clearance height similar to the robot's own body	Place a physical barrier in front of that furniture, or set a Virtual Boundary in the HOME App to prevent the robot from entering that area.
Driving wheels are blocked	A foreign object is wrapped around or stuck in the driving wheels	Rotate and press each driving wheel to check for obstructions. If a foreign object is found, remove it. If the problem persists after cleaning, please contact after-sales service.
Driving wheel alarm triggered	The driving wheel is tangled with hair or objects and has become stuck	Turn the robot off and place it upside down. First turn the wheel counterclockwise, then clockwise, to dislodge any hair or objects caught inside. Press and slide both driving wheels simultaneously to check that they rotate freely and spring back when released.
Abnormal noise during cleaning	The roller brush, side brush, driving wheel, or universal wheel is tangled with hair or objects	Power off the robot before cleaning. Remove the affected parts and clear any entangled hair or objects. Refer to the Regular Care & Maintenance section for detailed instructions.

Issue	Possible Cause	Solutions
	The dust baffle at the air inlet of the dust box is stuck	Remove the dust box and adjust the dust baffle to ensure it moves freely.
Unusually loud operation	Suction power is set to the highest level	Consider using a lower or mute suction setting when you are at home. Reserve the high suction setting for use when the property is unoccupied.
Robot is unable to return to the charging base	The charging base is not positioned correctly	Position the charging base as described in the 'Robot Charging' section of this manual: flat against a wall, with at least 1 m of clear space on each side and 2 m in front.
	The charging base has been switched off or moved during operation	Ensure the charging base remains powered on and in its original position throughout the cleaning session. Do not move it while the robot is working.
	The robot did not start cleaning from the charging base	It is recommended to always start cleaning from the charging base so the robot can reliably navigate back to it.
	The return path is blocked — for example, the door to the room containing the charging base is closed	Ensure the route back to the charging base is unobstructed throughout the cleaning session.

Issue	Possible Cause	Solutions
Robot returns to the charging base before finishing cleaning	The cleaning area is large and the battery ran low before the session was complete	Enable Continuous Cleaning in the App. The robot will automatically return to recharge and then resume cleaning where it left off. Refer to the App instructions for details.
	Certain areas are blocked by furniture or other barriers, preventing the robot from completing its route	Tidy the area before cleaning by moving furniture and small objects out of the robot's path.
Water tank or dust box falls off	The component was not installed securely	When fitting the water tank or dust box, push firmly until you hear an audible click to confirm it is locked in place.
Water tank is installed but there is no water flow, or only very little water seepage	The water tank is empty	Refill the water tank.
	The water tank outlet is blocked	Clear the outlet of the water tank.
	The mop holder is not installed	Attach the mop holder before use.
Water tank is leaking	The water inlet lid is not fully closed	Ensure the water inlet lid is closed tightly and securely.
Robot does not clean at the scheduled time	The scheduled appointment was cancelled	Set a new scheduled appointment in the App.

Issue	Possible Cause	Solutions
	The robot's battery is too low to begin the scheduled session	Charge the robot fully before the scheduled start time.
	Do Not Disturb (DND) mode is active	Scheduled cleaning will not run during DND hours. Adjust the DND time window in the App, or schedule cleaning at a different time.
Breakpoint resume (Continuous Cleaning) does not activate	Do Not Disturb mode is active	Continuous Cleaning will not resume during DND hours. Adjust the DND time window in the App, or run the cleaning session at a different time.
	The robot did not return to the charging base automatically at the end of the last session	If the robot was manually placed on the charging base rather than returning on its own, Continuous Cleaning will not activate. The next session will start fresh.
Fan is abnormal	The fan is tangled or blocked by a foreign object	Turn off the robot and take it to an authorised after-sales service centre for professional maintenance.

SPARE PARTS

Spin Mop Pad 4pk	31400362
Maintenance Kit	32300012



*Two years warranty on parts and labour excluding the battery which has a one year warranty.

Your Wertheim cleaner, in the case of domestic use, has a two year parts and labour warranty against product defects and failures when the product is used in accordance with the terms and conditions of this warranty statement.

This warranty commences from the original date of purchase and is not transferable; please retain your original proof of purchase for any warranty claims. This warranty is valid only in the country where the cleaner is purchased.

The cleaner must be operated in accordance with these instructions and used only for domestic household cleaning to remove dirt and dust from household carpets, flooring and fabrics. This cleaner is not fit to be used as an industrial cleaner, and is not designed for the collection of vitreous building material including particle board, construction products and similar products such as wood/fibres, cement, fillers, fibre glass etc or excessive or frequent sand. The infrequent pick-up of these materials in these circumstances may be harmful to your cleaner and may void the manufacturer's warranty.

Accessories and consumables including brush rollers and filters, unless defective in manufacture, are not subject to this warranty. In order to prolong the life of accessories and consumables, regular care and maintenance is recommended.

When properly used and cared for, your cleaner will render excellent service; refer to the instruction manual for further details, as misuse or failure to follow the instructions makes this warranty void.

In the event of service or advice being needed, or if you would like to make a claim under this warranty, please immediately stop using the machine and contact Godfreys Commercial, 2 Drake Boulevard Altona, VIC 3018, or on 131 929, Monday-Friday 9am-5pm AEST or

commercialsupport@godfreys.com.au.

The decision to repair or replace the cleaner is at the discretion of Godfreys Commercial depending on the circumstances and requirements of any applicable law. If Godfreys Commercial decide to repair or replace your Wertheim cleaner, it will do so at its own cost. Any transportation costs involved in a claim under this warranty shall be borne by the claimant.

Godfreys Commercial is unable to accept responsibility under this warranty for any repair work not carried out by an authorised Service Agent, or any defect arising from or in connection with the use of non-genuine parts. If any part is no longer available or manufactured, Godfreys Commercial will replace it with a genuine functional replacement part. This warranty does not apply to the cost of replacing any parts of the Wertheim cleaner due to normal wear and tear, alterations, improper installation, physical abuse, misuse or accidental damage.

If proof of purchase cannot be provided at the time of a warranty claim or service, any work carried out on the Wertheim cleaner will be at claimant's cost.

The repair of the Wertheim cleaner under this warranty does not extend the original period of warranty. If your Wertheim cleaner is replaced under this warranty, the replacement will be covered by this warranty for the remainder of the original warranty period. However, you may still have statutory rights after this time.

The benefits conferred by this warranty are in addition to all other rights and remedies in respect of the product as outlined under the Competition and Consumer Act 2010 (Cth) and other State and Territory laws.

Our goods come with guarantees that cannot be excluded under the Australian Consumer Law. You are entitled to a replacement or refund for a major failure and compensation for any other reasonably foreseeable loss or damage. You are also entitled to have the goods repaired or replaced if the goods fail to be of acceptable quality and the failure does not amount to a major failure.

Future Innovation Holdings Pty. Ltd.
trading as Godfreys Commercial
ABN: 98 677 632 021
2 Drake Boulevard Altona, Victoria 3018

Customer Support:
131 929

www.godfreys.com.au
commercialsupport@godfreys.com.au
Wertheim® is a registered trademark.