



WERTHEIM

SPINBOT PRO

SELF-EMPTY ROBOT VACUUM & SPIN MOP



SPINBOT PRO

FEATURES

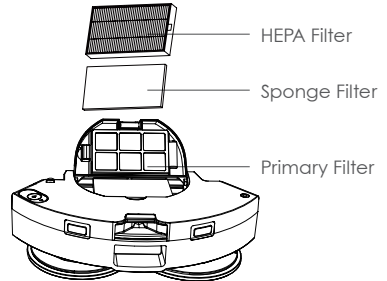
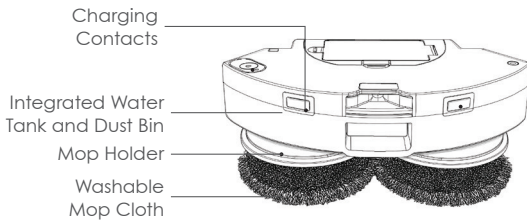
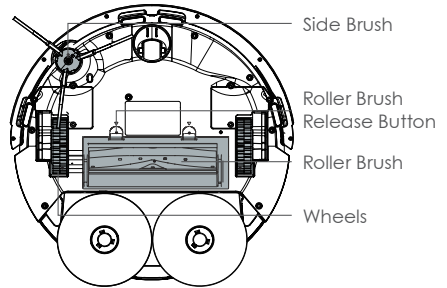
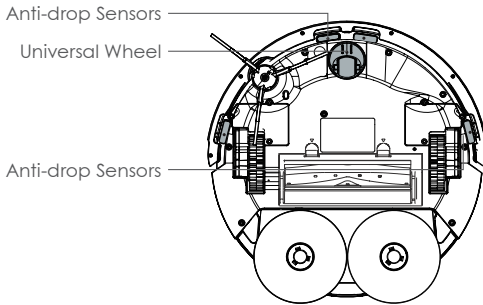
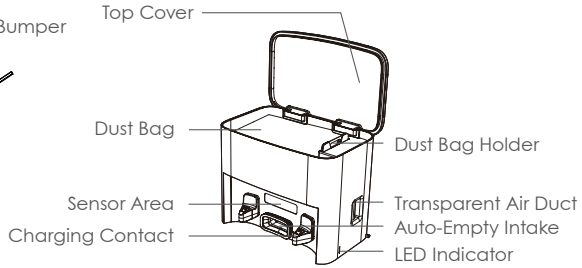
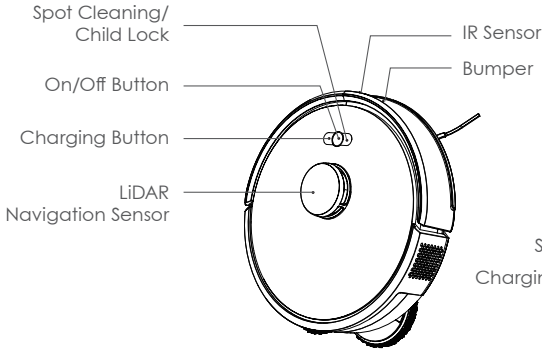

WHAT'S IN THE BOX

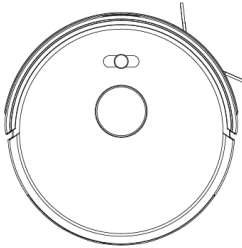

Robot Vacuum Cleaner

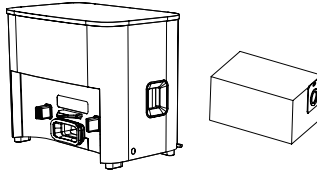

Self-empty Base
& Dust Bag

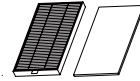

HEPA Filter Assembly

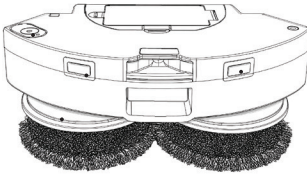

2-in-1 Water Tank & Dustbin
(Includes washable mops and brackets)

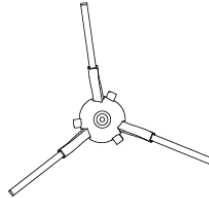

Side Brush



Cleaning Tool



Roller Brush



User Manual

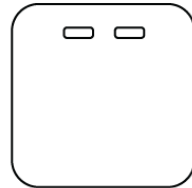

Moisture Barrier Pad



Introduction

Congratulations on the purchase of your new Wertheim SpinBot Pro Robot Vacuum. There are many useful features built into your cleaner. We recommend that you carefully read this instruction manual to take the best advantage of these features.

Specifications

Battery: 14.4V/4500mAh Li-ion battery
Battery Runtime: 200 min
Charging Time: 4-5 Hours
LiDAR Navigation

Dust Bin Capacity: 160ml
Water Tank Capacity: 230ml
Net Weight: 2.77kg(robot)
Gross Weight: 6.79kg

BEFORE YOU BEGIN

This cleaner must be operated in accordance with these instructions and used only for domestic household cleaning.

This cleaner is not fit to be used as an industrial cleaner and will void the manufacturer's warranty if used inappropriately.

Please read these instructions thoroughly

This will ensure you obtain full benefit from your new cleaner. Keep this instruction manual in a handy place for future reference.

Important

Always switch off the cleaner before cleaning, when not in use, attempting any maintenance task, fitting or removing accessories. The self-empty base must only be connected to an ac power supply at the voltage shown on the rating label. This cleaner should only be charged with the charger provided. This cleaner should only be used for its intended purpose as described in these instructions.

PRECAUTIONARY MEASURES:



1. **Do not** operate the cleaner too close to heaters, radiators or other hot surfaces.



2. Before inserting the plug into the wall, make sure your hands are dry.



3. Before turning on the cleaner, safely remove any large objects from the floor or cleaning surface in order to prevent damage to the brush roller.



4. When you want to remove the plug from the power socket, **do not** use the power cable, gently pull the plug from the power socket.



5. **Do not** use this vacuum cleaner if the battery pack housing and/or the charger housing is damaged.

SAFETY INSTRUCTIONS



DANGER
Live Parts
Within

IMPORTANT! Always switch off the cleaner before cleaning, when not in use or attempting any maintenance task, fitting or removing accessories. The charger must only be connected to an AC power supply at the voltage shown on the rating label. This cleaner should only be used for its intended purpose as described in this instruction manual. Never operate the cleaner without filters.

When using your cleaner, basic precautions should always be observed, including the following:

1. This appliance is not intended for use by persons (including children) with reduced physical, sensory, or mental capabilities, or lack of experience and knowledge, unless supervised or instructed by a person responsible for their safety.
2. Children must be supervised at all times to ensure they do not play with the appliance.
3. To prevent electric shock, do not immerse the appliance, battery, or power plug in water or any other liquid.
4. Do not use the vacuum cleaner outdoors or on wet surfaces.
5. Always inspect the power cord and plug before use. Do not use if damaged. If the power cord is defective, it must be replaced by the manufacturer, its service agent, or a qualified technician to avoid hazard.
6. This appliance and its self-empty base are intended for indoor domestic use only.
7. Do not unplug by pulling on the power cord. Always grasp the plug. Use only electrical extension cords approved for Australia and New Zealand.
8. Do not pull or carry the appliance by the power cord. Do not use the cord as a handle or pull it over sharp edges or corners. Avoid running the appliance over the cord.
9. Do not handle or operate the appliance with wet hands. Always follow electrical safety precautions.
10. Keep the vacuum cleaner away from heaters, radiators, and other hot surfaces.
11. Do not use the appliance to pick up flammable or combustible materials (e.g. gasoline, hot ashes, cigarettes, matches, or burning objects), or in areas where such materials may be present.

12. Do not use the appliance to pick up toxic substances (e.g. chlorine bleach or ammonia).
13. Do not operate the appliance without filters installed.
14. Before use, remove large or sharp objects from the cleaning area to prevent damage to the appliance, filters, or surfaces.
15. If the air inlet becomes blocked, switch off the appliance immediately. Clear the blockage before restarting.
16. Always switch off the appliance before performing maintenance or cleaning the filters.
17. Keep all openings away from your face and body.
18. Do not use the vacuum cleaner if it is damaged or not functioning properly. If any connection cables are damaged, they must be replaced immediately by a qualified technician.
19. Do not clean the vacuum cleaner or any electrical components, including electrical connections, with water or liquid cleaners.
20. Do not attempt to modify the vacuum cleaner or self-empty base in any way.
21. Store the appliance and charger indoors in a cool, dry place.

Battery use and care

1. This appliance must only be used with the charger supplied with the product.
2. Charge the battery only while it is installed in the appliance, using the designated charger provided.
3. When not in use, keep the appliance away from metal objects such as paper clips, coins, keys, nails, or screws. Contact between terminals may cause a short circuit, resulting in burns or fire.
4. Under extreme conditions, battery liquid may leak. Avoid contact. If contact occurs, rinse immediately with water. If liquid comes into contact with eyes, seek medical attention. Battery liquid may cause irritation or burns.
5. Do not charge or store the appliance outdoors or inside a vehicle. Charge and store the appliance in a dry indoor environment with a temperature between 5°C and 45°C. The charger is for indoor use only.
6. Do not attempt to open or disassemble the battery. If the battery casing is damaged or cracked, discontinue use immediately and do not recharge.
7. The charger adapter contains internal electrical components and is not serviceable.
8. Before disposing of the battery, fully discharge it by running the appliance until it stops.
9. This appliance contains a lithium battery. Do not dispose of it with

household waste. Contact your local council for safe disposal instructions.

10. Do not use the charger to charge non-rechargeable batteries.
11. Do not touch or insert objects into the battery terminals.
12. Do not short-circuit the battery terminals.
13. This appliance contains non-replaceable battery cells.

Risk of Damage

1. Lightweight or movable objects may be dragged by the robot vacuum, potentially causing damage to the object or floor surface.
2. Remove any loose or lightweight items from the cleaning area before use.
3. Secure any exposed or hanging cables (e.g. from floor lamps) to prevent entanglement or damage.

Risk of Fire

1. Do not operate the robot vacuum near heaters, radiators, or other hot surfaces.
2. Do not spray or pick up flammable liquids, cleaning agents, aerosols, or their vapours, as this may increase the risk of fire or explosion.
3. Do not use the robot vacuum to pick up burning or glowing materials, such as embers or cigarette butts.
4. Do not expose the battery to open flames or external heat sources.

Laser Navigation Sensor

1. This appliance contains a Class 1 rotating laser sensor for navigation.
2. The following safety precautions must be observed:
 - Switch off the robot vacuum before performing any maintenance or adjustments.
 - Do not aim the laser beam at people.
 - Do not look directly at the laser beam or its reflections.
3. Modifications or repair attempts to the device, particularly the navigation sensor, are strictly prohibited.

ASSEMBLY

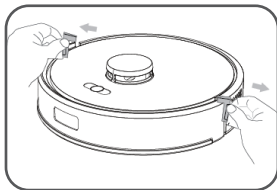

1. Before first use, remove all protective strips and films from both the robot and the self-empty base.

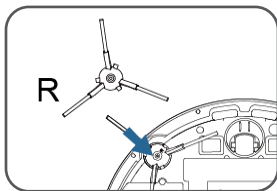

2. Install the side brushes securely onto the robot.

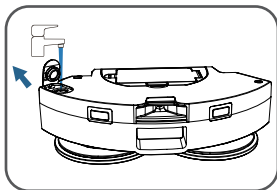

Install Water Tank & Dust Bin

1. Open the cover and fill the water tank with clean water. Ensure the water level is appropriate before closing the lid.



Warning: Do not add detergent, chemicals, bleach, eucalyptus oil, or any other substances to the Water Tank. Use clean water only. Adding any other substances may damage the Water Tank and internal components, and will void the warranty.

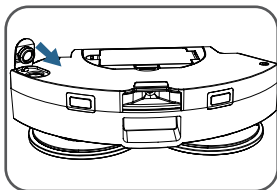

2. Close the water inlet cover securely, making sure it is fully sealed with no raised edges to prevent leakage.

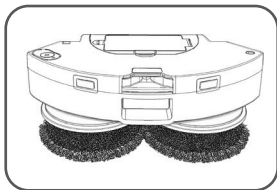

3. Attach the mop holder and secure the mop cloth firmly in place. Ensure it is aligned properly before use.

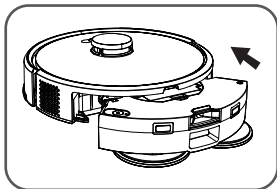

4. Press and hold the release button, then insert the integrated water tank and dust bin into the robot until it clicks into place.

Important Tips:

1. Use purified or soft water to extend product life
2. Do not use the mopping function on carpets
3. Empty the water tank and remove the mop holder after use
4. With mop installed: vacuum and mop simultaneously (suction defaults to low)
5. Without mop: vacuum-only mode
6. A small amount of water residue may remain due to factory testing

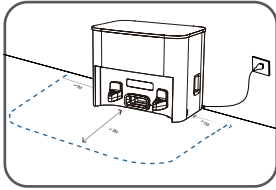

Charging the Robot

1. Place the self-empty base on a flat surface against a wall and attach the moisture barrier pad to the bottom of the self-empty base. Ensure there are no obstacles, stairs, or drop-offs within:
 - 1 metre on both sides
 - 2 metres in front
2. Connect the self-empty base to the power supply.
3. Long press the power button for 3 seconds to turn on the robot, then place it onto the self-empty base, ensuring the charging contacts align correctly.
4. For first use, please fully charge the robot. During charging, the Start button will flash with a white breathing light. Once fully charged, the light will flash white and the robot will enter standby mode after 10 seconds. Charging time is approximately 4–5 hours.

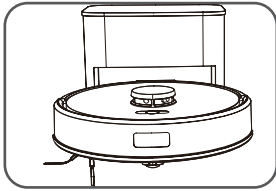



Important Notes

1. During daily use, always keep the robot on the self-empty base, ensure the base is connected to power, and ensure the robot is powered on.
2. Regularly clean the charging contacts to maintain optimal charging performance.
3. If the robot will not be used for an extended period, fully charge it before switching it off, then store it in a dry, ventilated area. Charge it once a month to protect the battery.
4. If the battery has been unused for a long time or becomes over-discharged, it may not charge properly. Contact customer service for assistance. Do not attempt to disassemble the unit.



Additional Tips

1. Keep reflective surfaces (e.g. mirrors or glass) away from the self-empty base.
2. Avoid placing the self-empty base in direct sunlight.
3. For first-time use, fully charge the robot before operation.
4. Typical charging time is approximately 4–5 hours.
5. The robot cannot be charged when it is powered off.

PRECAUTIONS

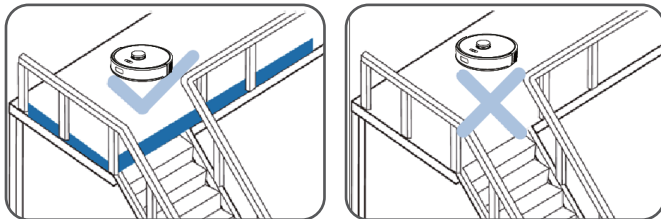

1. **Ensure safe operation near edges**

When cleaning near stairs or edges, observe the robot to ensure safe operation

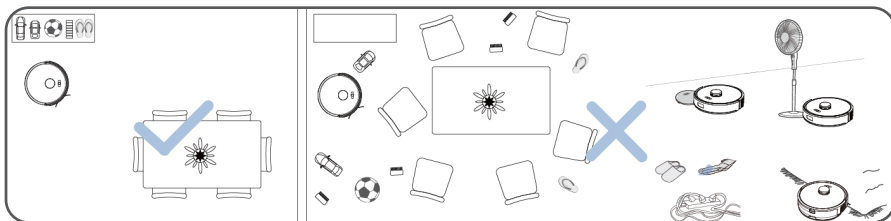

1. **Remove obstacles and entanglement hazards**

Clear all objects that may obstruct or entangle the robot, such as power cords, ropes, or loose items. High steps or uneven surfaces may cause the robot to become stuck.

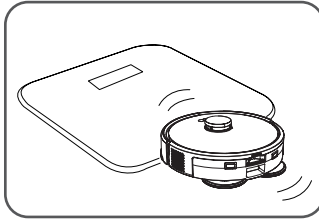
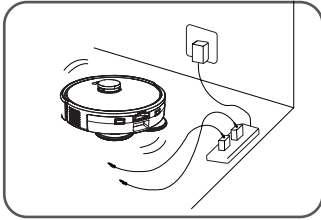

1. **Prepare the cleaning area**

Arrange furniture and remove obstacles in advance to ensure smooth operation. Low-profile objects (e.g. weighing scales or fan bases) should be removed or covered to avoid interference.

2. **First-time use and surface preparation**

For first-time use, monitor the robot during operation to identify potential issues and ensure efficient cleaning. Avoid standing directly in front of the robot while it is moving. Tuck in carpet edges or tassels to prevent entanglement.

INSTRUCTIONS FOR USE

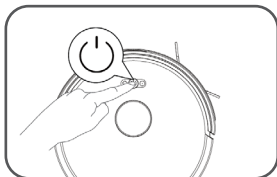

1. **START Button**

- Power On / Off: Long press for 3 seconds to power the robot on or off.
- Start / Pause: Short press to start cleaning. Short press again to pause.
- Wake Up: If the robot has been paused for more than 4 hours, the indicator light will turn off. Long press to wake the robot up.

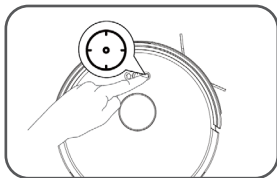

2. **SPOT CLEANING Button**

- Spot Clean: Short press to clean a 1.5m × 1.5m area centred around the robot's current position.
- Child Lock: Long press for 3 seconds to activate or deactivate Child Lock. When enabled, all physical buttons and smart speaker controls are disabled. The robot can still be controlled via the App.

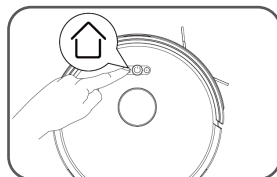

3. **CHARGING Button**

- Return to Charge: Short press to send the robot back to the self-empty base for charging and dust collection.
- Reset: Long press to reset the robot.

APP SETUP & FEATURES



Connect to the APP

- 1. Download the App**
Scan the QR code on the Self-empty base to download and install the VacConnect App, or search for it directly in the App Store (iOS) or Google Play Store (Android).
- 2. Create an Account**
Open the VacConnect App and create a new account, or log in if you already have one.
- 3. Add the robot cleaner**
Go to My Device, tap "+" in the upper right corner, then follow the in-app instructions to add your robot cleaner.
- 4. Enter Configuration Mode**
If the robot cleaner does not connect, press and hold the Charging Button and Spot Cleaning Button together for 3 seconds until you hear a voice prompt, then follow the in-app steps to complete setup.



Important Notes

1. App requires iOS 13.0 or above, or Android 6.0 or above.
2. Ensure your smartphone is connected to your home network before setup.
3. The SpinBot Pro supports 2.4 GHz Wi-Fi only. Select the 2.4 GHz network during setup.
4. If no Wi-Fi is available, use your smartphone's Personal Hotspot to connect the SpinBot Pro.

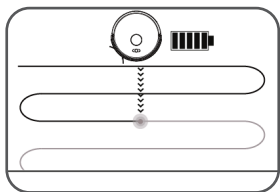

Breakpoint Resume

If the battery runs low during cleaning, the SpinBot Pro will automatically return to the Self-empty base to recharge, then continue cleaning from where it left off.

Note: The SpinBot Pro will not resume cleaning if Do Not Disturb mode is active, or if it was manually moved or recharged.

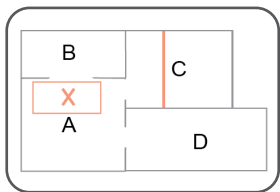

Restricted Area

Set No-Go Zones, No-Mop Zones, or virtual walls on the map to prevent the SpinBot Pro from entering certain areas. No-Mop Zones are only active when the Mop Holder is installed.

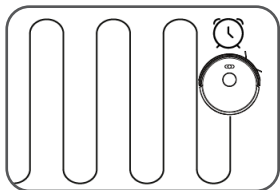

Scheduled Cleaning

Set a cleaning schedule in the App. The SpinBot Pro will clean automatically at the set time and return to the Self-empty base when finished.

Note: Scheduled cleaning will not run if the SpinBot Pro is in low battery or Do Not Disturb mode.

More Functions

The VacConnect App also includes: Real-Time Map View, Cleaning Mode Settings, Maintenance Schedule, Cleaning History, Remote Mode, Robot Status, Remaining Power, Positioning Robot, Firmware Updates, Voice Settings, and Do Not Disturb (DND) Mode.

MAINTENANCE

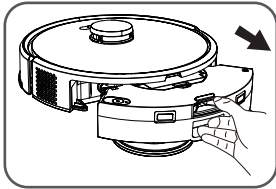

Cleaning Water Tank & Dust Bin

1. Press and hold the release key and pull out the Integrated Water Tank & Dust Bin.

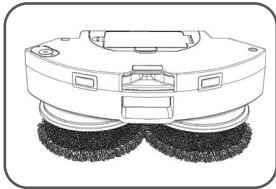

2. Remove the Mop Holder and Mop Cloth.

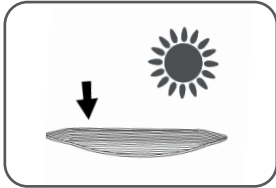

3. Wash and air-dry the Mop Cloth.

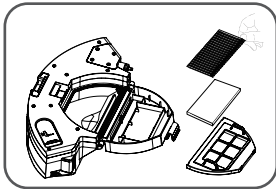

4. Open the dust bin and remove the Primary Filter, HEPA Filter, and Filter Sponge.

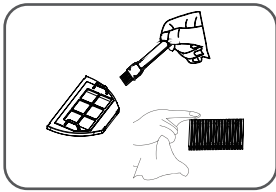

5. Clean the Primary Filter with the cleaning tool brush. Tap the HEPA Filter to remove dust.

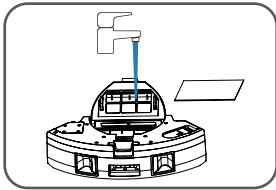

6. Wash the dust bin and Filter Sponge with water. Do not wash the HEPA Filter — if it gets wet, air-dry it before use.

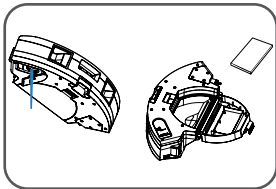

7. Empty and air-dry the Water Tank, dust bin, and Filter Sponge in shade before storing.

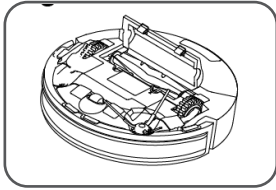

Cleaning Roller Brush & Side Brush

1. Pull the release tabs to unlock the brush guard.

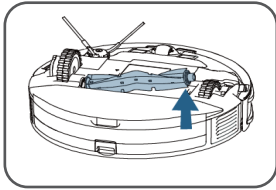

2. Lift out the Roller Brush.

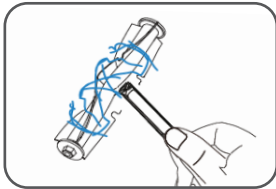

3. Clean the Roller Brush with the cleaning tool brush.

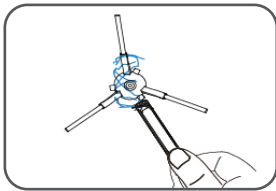

4. Clean the Side Brush with the cleaning tool brush.

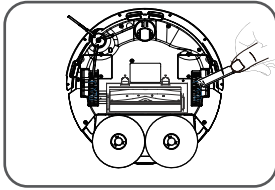

Cleaning Driving Wheel & Universal Wheel

1. Use the cleaning tool brush to remove hair and debris from the Driving Wheel.

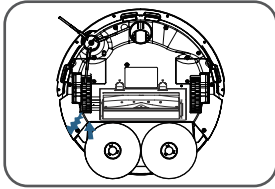

2. If the Driving Wheel is stuck, flip its gear in the opposite direction to release any trapped debris.

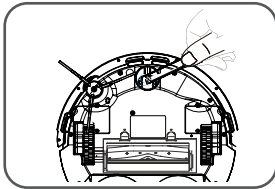

3. Use the cleaning tool brush to remove hair and debris from the Universal Wheel.

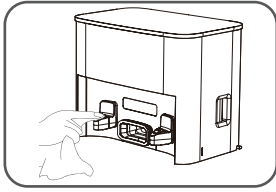

Cleaning Charging Contacts & Anti-drop Sensors

1. Wipe the charging contacts on the Self-empty Base with a dry cloth to remove any dirt or buildup.

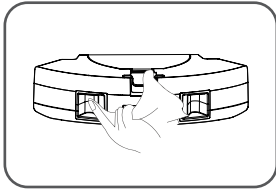

2. Wipe the charging contacts on the underside of the Robot with a dry cloth to ensure a reliable connection.

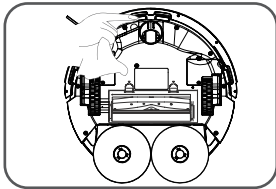

3. Wipe the Anti-drop Sensors on the underside of the Robot with a dry cloth to maintain accurate detection.

Warning: The charging contacts and Anti-drop Sensors contain sensitive electronic components. Always use a dry cloth when cleaning — never use a wet cloth, as moisture may cause damage.

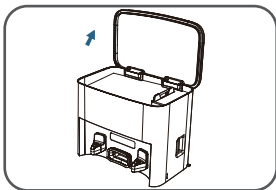

Cleaning the Self-empty Base

1. Wipe the charging contacts on the Self-empty Base with a dry cloth to remove any dirt or buildup.

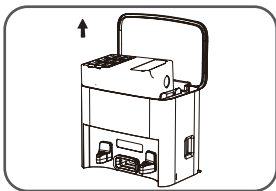

2. Lift and remove the full dust bag from the base.

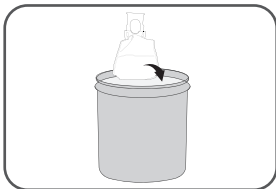

3. Hold the handle to carefully lift the dust bag out. Holding the handle during removal helps prevent dust from escaping.

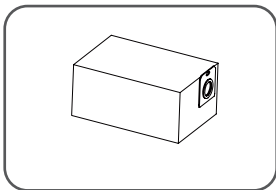

4. Insert the new filter and install a new dust bag.

Warning: To maintain effective dust collection, it is recommended to replace the dust bag promptly and clean the filter and air duct on a regular basis.

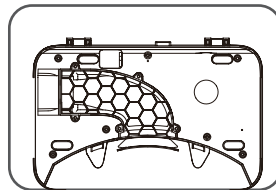

5. Unscrew the lower housing screws of the air duct cover, then remove the air duct shell and clean the air duct thoroughly.

TROUBLESHOOTING

Problems and Solutions

Please contact Godfreys Commercial Customer Support on 131 929 to find your local spare parts provider.

Issue	Possible Cause	Solution
Robot cannot power on	Battery is depleted	Charge the robot before use.
	Ambient temperature is outside the operating range	Use the robot in an environment between 0 °C and 40 °C.
Robot fails to start cleaning	Battery is depleted, or the side brush, roller brush, Dust Bin, or filter are clogged or tangled	Charge the robot. Check for any error alerts. It is recommended to regularly clean and maintain the side brush, roller brush, Dust Bin, and filter.
Reduced cleaning performance	The Dust Bin is full	Empty and clean the Dust Bin.
	The filter is clogged	Remove and clean the filter.
	The roller brush is entangled with hair or objects	Remove and clean the roller brush. Refer to the Regular Care & Maintenance section for instructions.
Robot is unable to charge	The Auto-Empty Station is not connected to the power supply	Ensure the Auto-Empty Station is plugged in and that its indicator light is on.

Issue	Possible Cause	Solution
	The robot's charging contacts are not properly connected to the Auto-Empty Station charging contacts, or the contacts are dirty	Seat the robot securely on the Auto-Empty Station and confirm the START button is flashing. If the contacts appear dirty, clean them as described in the Regular Care & Maintenance section of this manual.
	Ambient temperature is outside the charging range	Charge the robot in an environment between 0 °C and 40 °C.
	The battery has been deeply discharged due to an extended period without use	It is recommended to use the robot regularly. If prolonged storage has resulted in a charging issue, please contact after-sales service for assistance.
Unable to install the App	The mobile operating system version is too old	The App requires iOS 13.0 or later, or Android 6.0 or later. Please update your device's operating system and try again.
Robot cannot connect to the App	The router username or password is incorrect	Reconfigure the router settings and ensure the correct username and password are entered.
	The robot is outside the router's Wi-Fi coverage area	Move the robot closer to the router to ensure it is within the network signal range.

Issue	Possible Cause	Solution
	The robot is not in configuration (pairing) mode	Ensure the robot is connected to power and switched on. Press the Charging Button and Spot Cleaning Button simultaneously for 3 seconds. The robot will announce a voice prompt to confirm it has entered configuration mode.
	The router is broadcasting on a 5 GHz network only	The robot only supports 2.4 GHz Wi-Fi. Please switch your connection to a 2.4 GHz or dual-band 2.4/5 GHz network.
	The wrong App has been downloaded	Scan the QR code on the Auto-Empty Station, or download the VacConnect App directly from your device's app store.
Map has been lost	The robot was moved manually, causing it to lose its position reference	Place the robot back on the Auto-Empty Station to allow it to relocate itself. Open the App, go to Map Storage, find the saved map, and tap 'Use Map' to restore it. If the issue persists, initiate a new mapping run.
Unable to create a map in the App	The robot did not start cleaning from the Auto-Empty Station	The robot must always begin a cleaning and mapping session from the Auto-Empty Station.

Issue	Possible Cause	Solution
	The robot was moved while it was working	Do not move the robot while it is actively cleaning, as this interrupts the mapping process.
	The cleaning session was not allowed to finish	Allow the robot to complete its cleaning run and return to the Auto-Empty Station before the map is saved.
Navigation errors during cleaning (e.g. disordered route, deviation, repeated cleaning, or small areas left uncleaned)	Scattered objects on the floor (cables, slippers, etc.) are disrupting the robot's path	Clear the floor of loose items before starting the robot. If any area is missed, the robot will return to clean it automatically — please do not interfere by moving the robot or blocking its route.
	The robot's driving wheels lost traction when crossing a step, threshold, or door strip, causing it to misread the overall floor plan	Close the door to the affected area and clean it separately. The robot will return to its starting point once it has finished that zone.
	Operating on a newly waxed, polished, or very smooth tile floor reduces traction between the driving wheels and the surface	Allow the floor wax or polish to dry completely before using the robot.
	The distance sensor is dirty or obstructed	Clean the distance sensor and remove any objects covering it.

Issue	Possible Cause	Solution
	Due to the home layout, the robot cannot access certain areas	Rearrange the home environment where possible to allow the robot to enter and clean those areas.
Robot reverses or backs away	There is an obstacle ahead	Clear the path in front of the robot.
	The front bumper is stuck	Tap the bumper gently to check whether something is caught in it.
	The anti-drop sensor lens is dirty	Clean the surface of the anti-drop sensor lens.
Robot becomes stuck during operation	The robot is tangled or obstructed by loose cables, drooping curtain fabric, or carpet fringe on the floor	The robot will attempt to free itself automatically. If it cannot, manually clear the obstacle and restart the robot.
	The robot is wedged under furniture with a clearance height similar to the robot's own body	Place a physical barrier in front of that furniture, or set a Virtual Boundary in the VacConnect App to prevent the robot from entering that area.
Driving wheels are blocked	A foreign object is wrapped around or stuck in the driving wheels	Rotate and press each driving wheel to check for obstructions. If a foreign object is found, remove it. If the problem persists after cleaning, please contact after-sales service.

Issue	Possible Cause	Solution
Abnormal noise during cleaning	The roller brush, side brush, driving wheel, or universal wheel is tangled with hair or objects	Power off the robot before cleaning. Remove the affected parts and clear any entangled hair or objects. Refer to the Regular Care & Maintenance section for detailed instructions.
	The dust baffle at the air inlet of the Dust Bin is stuck	Remove the Dust Bin and adjust the dust baffle to ensure it moves freely.
Unusually loud operation	Suction power is set to the highest level	Consider using a lower or mute suction setting when you are at home. Reserve the high suction setting for use when the property is unoccupied.
Dust leakage occurs during operation	The 2-in-1 water tank and Dust Bin module is not correctly installed, or the Dust Bin outlet is blocked	Ensure the module clicks firmly into place when installing. If the Dust Bin outlet is blocked, remove the module and clear the blockage.
Robot reservoir (2-in-1 module) falls out during use	The module was not installed securely	Push the module firmly into place until you hear an audible click confirming it is locked.

Issue	Possible Cause	Solution
Robot is unable to return to the Auto-Empty Station	The Auto-Empty Station is not positioned correctly	Position the Auto-Empty Station as described in the 'Robot Charging' section of this manual: flat against a wall, with at least 1 m of clear space on each side and 2 m in front.
	The Auto-Empty Station has been switched off or moved during operation	Ensure the Auto-Empty Station remains powered on and in its original position throughout the cleaning session. Do not move it while the robot is working.
	The robot did not start cleaning from the Auto-Empty Station	It is recommended to always start cleaning from the Auto-Empty Station so the robot can reliably navigate back to it.
	The return path is blocked — for example, the door to the room containing the Auto-Empty Station is closed	Ensure the route back to the Auto-Empty Station is unobstructed throughout the cleaning session.
Robot returns to the Auto-Empty Station before finishing cleaning	The cleaning area is large and the battery ran low before the session was complete	Enable Continuous Cleaning in the App. The robot will automatically return to recharge and then resume cleaning where it left off. Refer to the App instructions for details.

Issue	Possible Cause	Solution
	Certain areas are blocked by furniture or other barriers, preventing the robot from completing its route	Tidy the area before cleaning by moving furniture and small objects out of the robot's path.
Water tank or Dust Bin falls off	The component was not installed securely	When fitting the water tank or Dust Bin, push firmly until you hear an audible click to confirm it is locked in place.
Water tank is installed but there is no water flow, or only very little water seepage	The water tank is empty	Refill the water tank.
	The water tank outlet is blocked	Clear the outlet of the water tank.
	The mop holder is not installed	Attach the mop holder before use.
Water tank is leaking	The water inlet lid is not fully closed	Ensure the water inlet lid is closed tightly and securely.
Auto-Empty Station cannot collect dust when the robot returns	The Auto-Empty Station cover is open	Close the Auto-Empty Station cover.
	The dust bag is not installed	Install a dust bag and then close the Auto-Empty Station cover.
	The robot was manually moved to the Auto-Empty Station, so the auto-empty cycle was not triggered	Allow the robot to return to the Auto-Empty Station on its own. Do not manually place the robot on the station, as this will prevent automatic dust collection from activating.

Issue	Possible Cause	Solution
	Do Not Disturb (DND) mode is active in the VacConnect App, suppressing automatic dust collection	Disable Do Not Disturb mode in the VacConnect App, or start dust collection manually.
	The Auto-Empty Station detects that dust collection efficiency is low — the dust bag may be full or incorrectly seated	Replace the dust bag as described in the Maintenance section of this manual, then close the Auto-Empty Station cover. If the App indicates the dust bag is not full, remove and reinstall it.
	All of the above causes have been ruled out — there may be a fault with a component inside the Auto-Empty Station	Please contact after-sales service.
Dust collection fails (Auto-Empty Station runs but does not collect dust effectively)	The Auto-Empty Station detects that dust collection efficiency is low — the dust bag may be full or incorrectly seated	Replace the dust bag as described in the Maintenance section of this manual, then close the Auto-Empty Station cover. If the App indicates the dust bag is not full, remove and reinstall it.
	The Dust Bin outlet is blocked	Remove the 2-in-1 module and clean the Dust Bin outlet.
The inner side of the Auto-Empty Station is dirty	Fine dust particles have passed through the dust bag and settled on the inner surfaces of the station	Clean the inner side of the Auto-Empty Station.

Issue	Possible Cause	Solution
	The dust bag is torn or damaged	Replace the dust bag.
Robot does not clean at the scheduled time	The scheduled appointment was cancelled	Set a new scheduled appointment in the App.
	The robot's battery is too low to begin the scheduled session	Charge the robot fully before the scheduled start time.
	Do Not Disturb (DND) mode is active	Scheduled cleaning will not run during DND hours. Adjust the DND time window in the App, or schedule cleaning at a different time.
Breakpoint resume (Continuous Cleaning) does not activate	Do Not Disturb mode is active	Continuous Cleaning will not resume during DND hours. Adjust the DND time window in the App, or run the cleaning session at a different time.
	The robot did not return to the Auto-Empty Station automatically at the end of the last session	If the robot was manually placed on the Auto-Empty Station rather than returning on its own, Continuous Cleaning will not activate. The next session will start fresh.
Fan is abnormal	The fan is tangled or blocked by a foreign object	Turn off the robot and take it to an authorised after-sales service centre for professional maintenance.

SPARE PARTS

Maintenance Kit	32300012
Dust Bag 5pk	32440613
Mop Pad 4pk	31400362



*Two years warranty on parts and labour excluding the battery which has a one year warranty.

Your Wertheim cleaner, in the case of domestic use, has a two year parts and labour warranty against product defects and failures when the product is used in accordance with the terms and conditions of this warranty statement.

This warranty commences from the original date of purchase and is not transferable; please retain your original proof of purchase for any warranty claims. This warranty is valid only in the country where the cleaner is purchased.

The cleaner must be operated in accordance with these instructions and used only for domestic household cleaning to remove dirt and dust from household carpets, flooring and fabrics. This cleaner is not fit to be used as an industrial cleaner, and is not designed for the collection of vitreous building material including particle board, construction products and similar products such as wood/fibres, cement, fillers, fibre glass etc or excessive or frequent sand. The infrequent pick-up of these materials in these circumstances may be harmful to your cleaner and may void the manufacturer's warranty.

Accessories and consumables including brush rollers and filters, unless defective in manufacture, are not subject to this warranty. In order to prolong the life of accessories and consumables, regular care and maintenance is recommended.

When properly used and cared for, your cleaner will render excellent service; refer to the instruction manual for further details, as misuse or failure to follow the instructions makes this warranty void.

In the event of service or advice being needed, or if you would like to make a claim under this warranty, please immediately stop using the machine and contact Godfreys Commercial, 2 Drake Boulevard Altona, VIC 3018, or on 131 929, Monday-Friday 9am-5pm AEST or

commercialsupport@godfreys.com.au.

The decision to repair or replace the cleaner is at the discretion of Godfreys Commercial depending on the circumstances and requirements of any applicable law. If Godfreys Commercial decide to repair or replace your Wertheim cleaner, it will do so at its own cost. Any transportation costs involved in a claim under this warranty shall be borne by the claimant.

Godfreys Commercial is unable to accept responsibility under this warranty for any repair work not carried out by an authorised Service Agent, or any defect arising from or in connection with the use of non-genuine parts. If any part is no longer available or manufactured, Godfreys Commercial will replace it with a genuine functional replacement part. This warranty does not apply to the cost of replacing any parts of the Wertheim cleaner due to normal wear and tear, alterations, improper installation, physical abuse, misuse or accidental damage.

If proof of purchase cannot be provided at the time of a warranty claim or service, any work carried out on the Wertheim cleaner will be at claimant's cost.

The repair of the Wertheim cleaner under this warranty does not extend the original period of warranty. If your Wertheim cleaner is replaced under this warranty, the replacement will be covered by this warranty for the remainder of the original warranty period. However, you may still have statutory rights after this time.

The benefits conferred by this warranty are in addition to all other rights and remedies in respect of the product as outlined under the Competition and Consumer Act 2010 (Cth) and other State and Territory laws.

Our goods come with guarantees that cannot be excluded under the Australian Consumer Law. You are entitled to a replacement or refund for a major failure and compensation for any other reasonably foreseeable loss or damage. You are also entitled to have the goods repaired or replaced if the goods fail to be of acceptable quality and the failure does not amount to a major failure.

Future Innovation Holdings Pty. Ltd.
trading as Godfreys Commercial
ABN: 98 677 632 021
2 Drake Boulevard Altona, Victoria 3018

Customer Support:
131 929

www.godfreys.com.au
commercialsupport@godfreys.com.au
Wertheim® is a registered trademark.