

vacspare

parts | accessories | commercial

COMMERCIAL POWERHEAD

FB400

NECK SIZE: 32 / 35MM



IMPORTANT

Congratulations on the purchase of your new commercial powerhead. Please take a moment to read this instruction manual, by following these procedures, your commercial powerhead will give you many years of efficient trouble-free service. **Keep these instructions in a safe place.**

This appliance is not intended for use by young children or infirm persons unless they are adequately supervised by a responsible person to ensure that they can use the appliance safely. **Young children should be supervised to ensure that they don't play with the appliance.**

WARNING! Seek advice from carpet manufacturers before using the motorised powerhead on woollen or delicate carpets.



1. **Do not** operate the commercial powerhead too close to heaters, radiators, and other hot surfaces.



2. Before inserting the plug into the machine, make sure your hand is dry.



3. Before turning on the commercial powerhead, remove any large or sharp objects from the floor or cleaning surface in order to prevent damage to the filter.



4. When you want to remove the plug from the vacuum cleaner, **do not** use the power cable, gently pull the plug from the power socket.



5. If the commercial powerhead or chrome tube is blocked, you should switch off the vacuum cleaner straight away and remove the commercial powerhead from the vacuum. First clear the blocked substance before attempting to start the commercial powerhead again.



**Live parts within the
commercial powerhead**

SAFETY PRECAUTIONS AND WARNING:

The commercial powerhead is an additional appliance for a select group of commercial vacuum cleaners and offers optimum cleaning of rugs as well as wall to wall carpeting. The particularly high brushing efficiency is complimented by good edge cleaning. If the electrical cord is replaced with Godfreys' cord (SKU: 33200065), this powerhead will also be compatible with the Pullman Commander PV900 Backpack Vacuum, the Pullman PV14 Commercial Backpack Vacuum and the Pullman AS5 Dry Commercial Vacuum.

IMPORTANT: Please be certain that the voltage on the rating plate matches the mains voltage.

Never touch the rotating brush roll! Guide the electric cord behind the unit and do not run the appliance over the cord.

1. **Do not** leave appliance plugged in. Unplug from vacuum when not in use and before removing or servicing.
2. **Warning** - electric shock could occur if used on wet surface.
3. Use only as described in this manual. Use only manufacturer's recommended attachments.
4. **Do not** continue to use this appliance if it appears to be faulty or damaged. If damaged, it must be repaired by the manufacturer or its service agent or a similarly qualified person in order to avoid a hazard.
5. **Do not** pull or carry the appliance by the cord, use the cord as a handle, close a door on the cord, or pull the cord around sharp edges or corners. **Do not** run the appliance over the cord and keep the cord away from hot surfaces.
6. **Do not** disconnect the appliance by pulling on the cord, only remove by using the plug directly when you have switched off the main power supply.
7. **Do not** handle the plug, cord or the appliance with wet hands.
8. **Do not** put any objects into openings. **Do not** use with any opening blocked, keep free of dust, lint, hair and anything that may reduce air flow.
9. Keep hair, loose clothing, fingers and all parts of the body away from openings and moving parts.
10. **Do not** pick up flammable materials such as thinners, petrol, acids, explosives or similar chemicals.
11. Always turn vacuum off before connecting or disconnecting the commercial powerhead.
12. If the supply cord is damaged, it **must be** replaced by the manufacturer, its service agent or similarly qualified persons in order to avoid a hazard.
13. This appliance is **not** intended for use by persons (including children) with reduced physical, sensory or mental capabilities or lack of experience and knowledge, unless they have been given supervision or instruction concerning use of the appliance by a person responsible for their safety.
14. To prevent electrical shock, **do not** immerse the appliance, power cord or power plug into water or other liquids.
15. Always check the power cord before use, the power cord and the plug should be in a good condition and **must not** be damaged. If the power supply cord is damaged or defective, it must be replaced by the manufacturer, its service agent or similarly qualified persons in order to avoid a hazard.
16. Extreme caution should be exercised when using the appliance on stairs.
17. **Do not** operate the vacuum cleaner too close to the heaters, radiators and other hot surfaces.
18. **Never** clean the powerhead or any of the electrical parts, especially the electrical connections with water or liquid cleaners.
19. Always store the appliance indoors in a cool and dry place.
20. **Do not** pickup water, for dry use only
21. **Never** run over the power cable with the powerhead as the cable could get damaged.
22. **Never** touch the roller brush while the vacuum cleaner is connected to the mains power.
23. To prevent unnecessary wear on the powerhead, cleaning the nozzle keeps it moving while in operation.
23. **WARNING:** The vacuum cleaner powerhead contains electrical connections. The powerhead is not a serviceable part.

GENERAL INFORMATION

Features

1. Fits on a variety of 32mm and 35mm vacuum rods, by using the adjustable universal adaptor.
2. Fitted with a rubber bumper to help protect furnishings and skirting damage while in use.
3. Fitted with a 4.5 metre power cord and 5 clips for secure fastening of the cord fastening to the rods and vacuum hose.
4. Made in Italy.
5. One Year Commercial Warranty.

Benefits

1. This universal commercial powered head for backpacks is easy to connect and will greatly improve the vacuum's performance on long, medium or short piled carpet surfaces.
2. Ideal for restaurants, offices, shops, cafes, schools, hotels and motels or when a large carpeted area requires vacuuming.
3. Delivers a deeper clean for better dirt removal than a conventional floor tool.
4. Reduces the cleaning time and effort for the cleaner by covering a larger area whilst being more efficient and easier to use.
5. Will assist in creating a healthier environment as it removes more allergy causing dust particles from carpeted floor coverings.
6. Excellent for pet hair removal due to its agitating brush.
7. Rejuvenates and lifts carpet fibres.

Assembly and Usage

1. Change the Belt every 6 to 12 months depending on the usage, as the belt will stretch over time.
2. The power head will automatically turn on when the vacuum is activated.

KNOW YOUR PRODUCT

1. Elbow and Adaptor (32mm/35mm compatible)
2. Cover
3. Furniture guard
4. Push pedal
5. Rear wheels
6. Cable
7. Brush roll
8. Screws

Technical Information

220-240V~50Hz
Net weight: 2.2kg

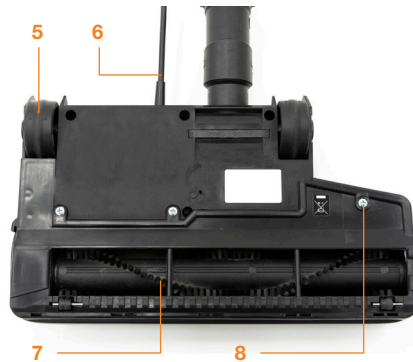

ASSEMBLY

Disconnect appliance from mains supply before assembling, disassembling or servicing.



DANGER
Live Parts
Within

Live parts within the
commercial powerhead



1. Unscrew the locking mechanism to gain access to the socket.



2. Remove the adaptor from the socket inlet.



3. Place the rod through the locking mechanism, and securely attach the adaptor to the rod below. Please see photo for reference.
*Rod not included.

ASSEMBLY

WARNING! Seek advice from carpet manufacturers before using a motorised powerhead on woolen or delicate carpets.



4. Once the rod has been inserted into the socket inlet, screw the locking mechanism back on securing the powerhead to the rod.



5. To ensure there are no tripping hazards, attach the cord to the safety clip and then attach the clip to the rod as pictured.



6. Connect the plug to the machines powerhead outlet socket securely for the powerhead to receive power.
Note: Do not unplug by pulling on the power cord. To unplug the powerhead, grasp the power plug and gently pull to remove from the powerhead socket.

OPERATION

Disconnect appliance from the mains supply before assembling, disassembling or servicing.



1. Place your foot on the PUSH pedal and pull the rod back to release the powerhead for use.



2. The fringe of carpet and rugs should only be cleaned in the direction of the arrows pictured.



**Live parts within
the commercial
powerhead**

MAINTENANCE

WARNING! Ensure the powerhead is not connected to the power supply when performing any maintenance procedures.

Note: Do not unplug by pulling on the power cord. To unplug the powerhead, grasp the power plug and gently pull to remove from the powerhead socket.



1. To gain access to the agitator, remove the cover by unscrewing the three screws located on the bottom of the powerhead.

WARNING: The vacuum cleaner powerhead contains electrical connections. The powerhead is not a serviceable part.



DANGER
Live Parts
Within

**Live parts within
the commercial
powerhead**



2. Remove the cover from the powerhead to gain access to the agitator and belt.



3. Maintain your agitator by regularly cleaning and removing any hair that may get caught around the brush.



4. Reinstall the agitator by reconnecting the end to the belt before securing the agitator back in place. Replace the cover and screws once completed.

TROUBLESHOOTING

WARNING! Ensure the powerhead is not connected to the power supply when performing any maintenance procedures.

Note: Do not unplug by pulling on the power cord. To unplug the powerhead, grasp the power plug and gently pull to remove from the powerhead socket.

TROUBLE	POSSIBLE CAUSE	REMEDY
Brush doesn't Spin	No power to the powerhead	Check that the powerhead socket is securely attached to the vacuum outlet, for further assistance please ensure a qualified service technician assesses the commercial powerhead for any electrical faults.
	Obstruction around the agitator	Ensure the powerhead is disconnected from the vacuum and clean the agitator, remove anything stopping the brush from spinning.
	Broken belt	Ensure the powerhead is disconnected from the vacuum and check to see if the belt is broken. If the belt is broken, please ensure a qualified service technician replaces the belt.



DANGER
Live Parts
Within

Live parts within
the commercial
powerhead

SPARE PARTS

Please contact Godfreys Commercial Customer Support on 131 929 to find your local spare parts provider.

PRODUCT DESCRIPTION	SKU
Agitator	33788191
Belt	32102319

Conditions of warranty



Your Vacspare Powerhead FB400, in the case of domestic use, has a one-year warranty against product defects and failures when the product is used in accordance with the terms and conditions of this warranty statement.

This warranty is provided by Future Innovation Holdings Pty Ltd Trading as Godfreys Commercial ABN 98 677 632 021. This warranty commences from the original date of purchase and is not transferable. You are required to retain your original proof of purchase for any claims under this warranty. This warranty is valid only in the country where the dehumidifier is purchased.

Your Vacspare Powerhead FB400 must be operated in accordance with these instructions and used only for moisture removal and humidity control in indoor environments. Failure to allow the unit to stand upright for 20 minutes after unpacking or accidental tip-over before starting will void this warranty. This warranty does not cover damage caused by operating the unit outside the temperature range of 33-110°F, or failing to maintain a 12-18 inch clearance space around the unit.

Accessories and consumables including filters, unless defective in manufacture, are not subject to this warranty. In order to prolong the life of accessories and consumables, regular care and maintenance is recommended.

Refer to the instruction manual for further regarding the use and care of your Vacspare Powerhead FB400, as misuse or failure to follow the instructions—including improper installation of the drain hose—voids this warranty.

In the event of service or advice being needed, or if you would like to make a claim under this warranty, please immediately stop using the Vacspare Powerhead FB400 and contact Godfreys Commercial, 2 Drake Boulevard Altona, VIC 3018, or on 131 929, Monday-Friday 9am-5pm AEST or commercialsupport@godfreys.com.au.

The decision to repair or replace the dehumidifier is at the discretion of Godfreys Commercial depending on the circumstances and requirements of any applicable law. If Godfreys Commercial decide to repair or replace your Vacspare Powerhead FB400, it will do so at its own cost. Any transportation costs involved in a claim under this warranty shall be borne by the claimant.

Godfreys Commercial is unable to accept responsibility under this warranty for any repair work not carried out by an authorised Service Agent, or any defect arising from or in connection with the use of non-genuine parts. If any part is no longer available or manufactured, Godfreys Commercial will replace it with a genuine functional replacement part. This warranty does not apply to the cost of replacing any parts of the Vacspare Powerhead FB400 due to normal wear and tear, alterations, improper installation, physical abuse, misuse or accidental damage.

If proof of purchase cannot be provided at the time of a warranty claim or service, any work carried out on the Vacspare Powerhead FB400 will be at claimant's cost.

The repair of the Vacspare Powerhead FB400 under this warranty does not extend the original period of warranty. If your Vacspare Powerhead FB400 is replaced under this warranty, the replacement will be covered by this warranty for the remainder of the original warranty period. However, you may still have statutory rights after this time.

The benefits conferred by this warranty are in addition to all other rights and remedies in respect of the product as outlined under the Competition and Consumer Act 2010 (Cth) and other State and Territory laws.

Our goods come with guarantees that cannot be excluded under the Australian Consumer Law. You are entitled to a replacement or refund for a major failure and compensation for any other reasonably foreseeable loss or damage. You are also entitled to have the goods repaired or replaced if the goods fail to be of acceptable quality and the failure does not amount to a major failure.

vacspare

parts | accessories | commercial