



Superpro 700 series

EN

Product & Training Manual

Corded Backpack Vacuum Cleaners

DA

Produkt- & træningsmanual

Rygsæk-støvsugere med ledning

FI

Tuote- ja koulutusopas

Johdolliset reppuimurit

FR

Manuel de Formation et d'Entretien du Produit

Aspirateurs dorsaux électriques

NL

Product- & trainingshandboek

Rugstofzuigers met snoer

SV

Produkt- och utbildningshandbok

Dammsugare med rygsäck



pacvac.com

Product & Training Manual

Corded Backpack Vacuum Cleaners

ENGLISH

Contents

English	8
General Safety Instructions	8
Product Specific Safety Instructions.....	9
Symbol Definitions	9
Specifications	10
Specifications - EU models.....	11
Product Fiche - EU models.....	11
Design Registrations.....	11
Safety and Maintenance Checks	12
Safe Disposal	12
Wear Right	13
Troubleshooting	14
Service Requirements.....	14
Warranty.....	15
Spare Parts	16
Optional Extras.....	18
EC Declaration of Conformity.....	19

CAUTION Read this Product & Training Manual before using the machine and instruct operators if applicable.
RETAIN FOR FUTURE REFERENCE.

This manual applies to the Pacvac Superpro 700 Series: Superpro 700, duo 700, micron 700, trans 700 and wispa 700 commercial backpack vacuum cleaners.

General Safety Instructions

WARNING To reduce the risk of fire, electric shock or injury, read all instructions before using. When using an electrical appliance, basic precautions should always be followed.

1. This manual shall be considered an integral part of the machine and should be carefully looked after for subsequent reference.
2. **WARNING** This machine is not suitable for picking up hazardous dust.
3. **WARNING** Do not allow the power cord to come into contact with rotating brushes of floor tools.
4. **WARNING** Do not use this machine in wet conditions.
5. **CAUTION** This machine shall be stored and used indoors only.
6. Remove the machine from packaging and ensure it and all its accessories and attachments are present and in perfect condition. Contact the place of purchase immediately in the event of any discrepancies.
7. The electrical specifications of this machine are noted on the data plate which is located near the power switch. Ensure the specifications correspond to those of the mains power supply in your area. If the machine is without a data plate, contact the place of purchase immediately.
8. **WARNING** This machine is intended for the vacuuming of dry dust and/or small debris off dry carpeted or hard floor surfaces in indoor areas only.
9. **WARNING** Do not use the machine without the dust bag and filters in place.
10. Do not restrict the vacuum cleaner's airflow. Maintain the vacuum cleaner regularly so that all filters and openings are free of dust, lint, hair build-up or anything else which may affect airflow. Refer to the Safety and Maintenance Checks in this Product & Training Manual.
11. Regularly check the power cord for damage, such as cuts, abrasions, exposed wiring or aging. If the power cord or plug is damaged, the complete power cord must be replaced by your local Authorised Pacvac Service and Warranty Agent in order to avoid an electric shock. The power cord should only be replaced with a Pacvac Genuine Spare Part with the same specifications.
12. If the machine has been dropped, damaged, left outdoors or has been exposed to liquids, return it to your local Authorised Pacvac Service and Warranty Agent for a safety check.
13. Do not use the machine to pick up flammable or combustible liquids, such as petrol etc. and do not use in areas where they may be present.
14. Do not vacuum anything that is burning or smoking such as cigarettes or hot ashes.
15. Do not vacuum up hard or sharp objects such as glass, nails, screws etc.
16. Keep hair, loose clothing, fingers and all parts of the body away from moving parts and openings.
17. Keep the machine and power cord away from heated surfaces.
18. Do not unplug the machine while it is turned on. Turn the machine off, turn the power off at the power outlet then unplug by grasping the plug and pulling gently to unplug.
19. Do not handle the machine, power cord or plug with wet hands.
20. Unplug from power point when not in use, before servicing or before changing filters and attachments.
21. Do not pull or carry the machine by the power cord.
22. Do not close doors on the power cord and do not pull the cord around sharp edges or corners.
23. Store in an appropriate place after use to prevent tripping accidents.
24. This appliance is not intended for use by persons (including children) with reduced physical, sensory or mental capabilities, or lack of experience and knowledge, unless they have been given supervision or instruction concerning use of the machine by a person responsible for their safety. Children should be supervised to ensure that they do not play with this machine.
25. (Applicable in Europe only) This appliance can be used by children aged from 8 years and above and persons with reduced physical, sensory or mental capabilities or lack of experience and knowledge if they have been given supervision or instruction concerning use of the appliance in a safe way and understand the hazards involved. Children shall not play with the appliance. Cleaning and user maintenance shall not be made by children without supervision. Use only the manufacturer's recommended attachments and/or replacement parts.

Product Specific Safety Instructions

1. **WARNING** Do not place the Superpro duo 700 model on the ground while the machine is turned on. This can result in irreparable damage to the motor.
2. **WARNING** Do not plug the Superpro trans 700 into a power supply other than 110-120V, 400Hz. An alternate power supply can cause irreparable damage to the motor and other electrical components.
3. The following models have a "A"-weighted emission sound pressure level (measured at 1.5 meters) of:
Superpro 700 - 67dB(A)
Superpro duo 700 - 74dB(A)
Superpro wispa 700 - 66dB(A) / 62dB(A) wispa mode
Superpro micron 700 - 65dB(A)
Superpro trans 700 - 63dB(A).
4. **WARNING** Only use the socket outlet on the machine for purposes specified within these instructions.
5. This appliance may be fitted with a power socket outlet (excludes wispa 700 model). A power socket outlet is designed for use with applicably approved electric powerhead attachments. Powerhead attachments use rotating brushes to agitate carpet fibres in order to dislodge dust and/or debris. Maximum wattage for such attachment shall not exceed 200 watts.
6. Floor Tool and all purpose use Part No. FLT001 - Floor Tool is intended for vacuuming of dry dust and debris off floor surfaces.
7. Part No. ACC001 - Dusting Brush is intended for vacuuming of dry dust from blinds and other delicate surfaces.
8. Part No. ACC002 - Crevice Tool is intended for vacuuming of dry dust and debris from crevices.
9. Part No. ACC003 - Upholstery Tool is intended for vacuuming of dry dust from upholstered surfaces.

Motor Thermostat

IMPORTANT: The motor is equipped with a thermostat. If for any reason, the vacuum cleaner should over-heat, the thermostat will automatically turn the unit off. Should this occur, turn off the switch and unplug the vacuum cleaner from the electrical outlet and conduct safety and maintenance checks. Allow the cleaner to cool for approximately 30 minutes. To re-start, plug into a power point and switch back on.

RETAIN THESE SAFETY INSTRUCTIONS FOR FUTURE USE.

Symbol Definitions

1. Attention!



2. Operator's Manual; Operating Instructions



Specifications

Model	Superpro 700	Superpro duo 700	Superpro micron 700	Superpro trans 700	Superpro wispa 700
Model No	01PR700VB	01DU700VB	01MI700VB	01TR700VB	01WI700VB
Volts/ Frequency	220-240V AC 50Hz	220-240V AC 50Hz	220-240V AC 50Hz	110-120V AC 400Hz	220-240V AC 50Hz
Motor	1000W two-stage flow through	1000W two-stage by-pass	1000W two-stage flow through	850W two-stage flow through	1300W single-stage flow through
Noise Level (at 1.5m)	67dB(A)	74dB(A)	65dB(A)	63dB(A)	66dB(A), 62dB(A) (wispa mode)
Filtration	4 stage, HEPA rated Hypercone™ filter	4 stage, HEPA rated Hypercone™ filter	4 stage, HEPA rated high-grade filter	4 stage, HEPA rated Hypercone™ filter	4 stage, HEPA rated Hypercone™ filter
Volumetric Airflow (Max.)	45L/s	45L/s	40L/s	36L/s	50L/s, 39L/s (wispa mode)
Capacity	5L	5L	5L	5L	5L
Weight (excluding power cord assembly and hose)	5.2kg	5.3kg	5.3kg	5.1kg	4.7kg
Power Source	Mains, 18m power cord	Mains, 18m power cord	Mains, 18m power cord	Mains, 18m power cord, hardwired	Mains, 18m power cord, (IEC C15)
Vibration Level	≤2.5m/s ²	≤2.5m/s ²	≤2.5m/s ²	≤2.5m/s ²	≤2.5m/s ²

Specifications - EU models

Model	Superpro 700	Superpro micron 700
Model No	02PR700VB	02MI700VB
Volts/Frequency	230V AC 50Hz	230V AC 50Hz
Motor	900W two-stage flow through	900W two-stage flow through
Noise Level (at 1.5m)	70.2dB(A)	69.8dB(A)
Filtration	4 stage, HEPA rated Hypercone™ filter	4 stage, HEPA rated high-grade filter
Volumetric Airflow (Max.)	53L/s	48L/s
Capacity	5L	5L
Weight (excluding power cord assembly and hose)	5.2kg	5.3kg
Power Source	Mains, 18m power cord	Mains, 18m power cord
Vibration Level	≤2.5m/s ²	≤2.5m/s ²

Product Fiche - EU models

In accordance with (EU) Regulation No 665/2013

Model ID	02PR700VB	02MI700VB
Energy class	C	C
Yearly Consumption	35.9kWh	35.2kWh
Dust pickup (carpet)	E	E
Dust pickup (hardfloor)	D	B
Dust emission	E	C
Sound power	79.4dB(A)	77.2dB(A)
Rated power	900W	900W

*Yearly consumption is an indicative of the annual energy consumption (kWh per year), based on 50 cleaning processes. The actual annual energy consumption depends on how the machine is used.

Creation date of the table: 02/2017

Design Registrations

EP Registered Design	001617051-0001
----------------------	----------------

*Technical specifications are subject to change without notice.

Safety and Maintenance Checks

DAILY

1. Replace the optional paper bag if needed. Remove, empty and clean the reusable dust bag.

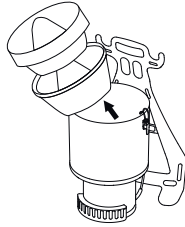

3. Check all power cords and ensure there are no cuts, abrasions or exposed wiring.

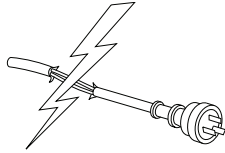

5. Wrap loosely the cable from the backpack towards the plug. Store power cord on the 'hook' on the frame.

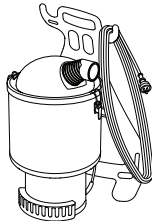

2. Remove the filter and tap gently to clean.

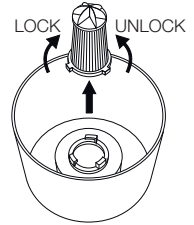

4. Check the floor tool, wand, handpiece and hose for any obstructions.

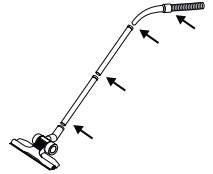

WEEKLY

- Remove and clean the external motor filter.

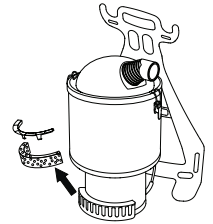

NOTE: Any other servicing should be performed by an Authorised Service & Warranty Agent. Please do not use if any damage is found.

Safe Disposal

Contact your local waste authority for information regarding available recycling and/or disposal options. Or contact Pacvac by emailing support@pacvac.com or phone +61 8 9479 1444 for the latest information.

Europe Only - When replacing old appliances with new ones, please check if the retailer is legally obligated to take back your old appliance for disposal.

Wear Right

In preparation of wearing the machine, follow these simple principles:

1



Wear comfortably

Loosen the shoulder straps and adjust the length, if required.

Lift the backpack by one shoulder strap and slide your free arm into the other strap.

2



Tighten harness hipband

Wrap the attached harness hipband around your hips and adjust to ensure a comfortable fit.

3

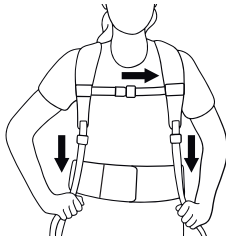

Adjust straps

Pull down on the shoulder straps until it feels comfortable.

Adjust the chest strap to the correct position for you, and click together to secure.

4

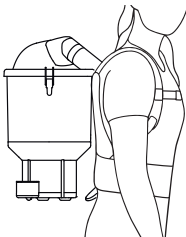

Correct posture

Make sure the machine is fitted comfortably to your frame.

IMPORTANT

If the backpack feels heavy or uncomfortable, it is likely you are not wearing it correctly. Contact Pacvac for further advice.

Troubleshooting

Caution: Always unplug the backpack before attempting to solve a problem or when servicing.

Problem	Cause	Solution
Backpack not working	Power cord not firmly plugged into power point, short lead, or machine.	Check all plugs and sockets are firmly plugged in.
	Backpack shuts off due to high motor temperature.	Turn main switch off and unplug the backpack. Conduct safety and maintenance checks found in this Product and Training Manual or as per labelling on the machine. After 30 minutes (60 minutes for wispa) the backpack should be ready for use. If not contact the number below for your nearest Authorised Pacvac Service and Warranty Agent.
	Circuit breaker or RCD has tripped.	Check the machine is in good working order. If OK, reset circuit breaker or RCD. If circuit breaker or RCD trips again contact your nearest Authorised Pacvac Service and Warranty Agent.
Backpack has no/poor suction.	Hypercone dust bag full.	Remove, empty and clean Hypercone dust bag.
	Hypercone dust bag not installed correctly.	Remove and empty dust bag making sure the rubber edging is correctly fitted around the canister.
	Hose not installed correctly.	Reconnect hose and ensure correctly sealed.
	Blockages.	Remove hose, wand and floor tools; remove any blockages.
	Filters blocked.	Clean Hypercone HEPA filter and external motor filter.

Service Requirements

Our products are designed and built to be functional and durable. For information on use and maintenance please read this Product & Training Manual thoroughly.

Should you require servicing contact your nearest Authorised Pacvac Service and Warranty Agent.

Warranty

Your Pacvac Pty Ltd (Pacvac) product has been manufactured to meet our highest quality standards. We urge you to take good care of your product and be sure to follow instructions carefully. This will provide you with the best possible performance and lifespan of the product.

The inclusion of the following paragraph is a requirement by Australian Law. It explains that consumers have rights by law regardless of any warranties provided or not by a manufacturer or supplier.

“Our goods come with guarantees that cannot be excluded under the Australian Consumer Law. You are entitled to a replacement or refund for a major failure and for compensation for any other reasonably foreseeable loss or damage. You are also entitled to have the goods repaired or replaced if the goods fail to be of acceptable quality and the failure does not amount to a major failure.”

In addition to the guarantees under Australian Consumer Law, Pacvac warrants all machines and their components against faulty material and / or workmanship for a period of two years from the date of purchase by the original consumer.

The following explains conditions and what to do in the event of a claim:

Pacvac will replace parts determined as faulty however this does not cover reasonable wear through normal use of any consumable parts, such as but not limited to, bags, filters, hoses, electrical leads, carbon brushes and floor tools etc.

Warranty does not cover any machine or component that has been altered, abused, neglected, modified, used with non-genuine Pacvac components or has not been used and maintained as indicated in this Product & Training Manual.

Warranty repairs can only be carried out by an Authorised Pacvac Distributor or Repairer. Visit our website for your nearest location. Warranty claims are limited to the original warranty period from the date of purchase. Warranty repairs and / or replacements do not extend the original warranty period.

All reasonable expenses associated with returning goods for a warranty claim are the consumer's responsibility.

Claims must be made within two years of the date of purchase and proof of purchase must be supplied with the claim.

To make a claim under warranty, take the product with proof of purchase to the place of purchase. If the place of purchase does not satisfactorily rectify the matter, please contact Pacvac.

Pacvac has the right to request pictures of warranty product failures or to request for those parts be returned to Pacvac's office in Western Australia.

The replacement of any part shall be at Pacvac's discretion.

 +61 8 9479 1444  support@pacvac.com  pacvac.com

Spare Parts

Quote these part numbers when ordering spare parts for all models.

No.	Part Name	Part No.
1.	Dusting brush 32mm	ACC001
2.	Crevice tool 32mm	ACC002
3.	Upholstery tool 32mm	ACC003
4.	Front motor filter cage	CAG001
5.	Plastic cord restraint	COR004
6.	Exhaust filter	FIL004
7.	All purpose floor tool 285mm	FLT001
8.	Combination floor tool ERP 270mm	FLT012
9.	Harness back and hip band	HAR001
10.	Hose assembly 1.2m	HOA014
11.	Clear lid 5L	LID001
12.	Padded shoulder strap	STP003
13.	Chrome two piece wand	WND002

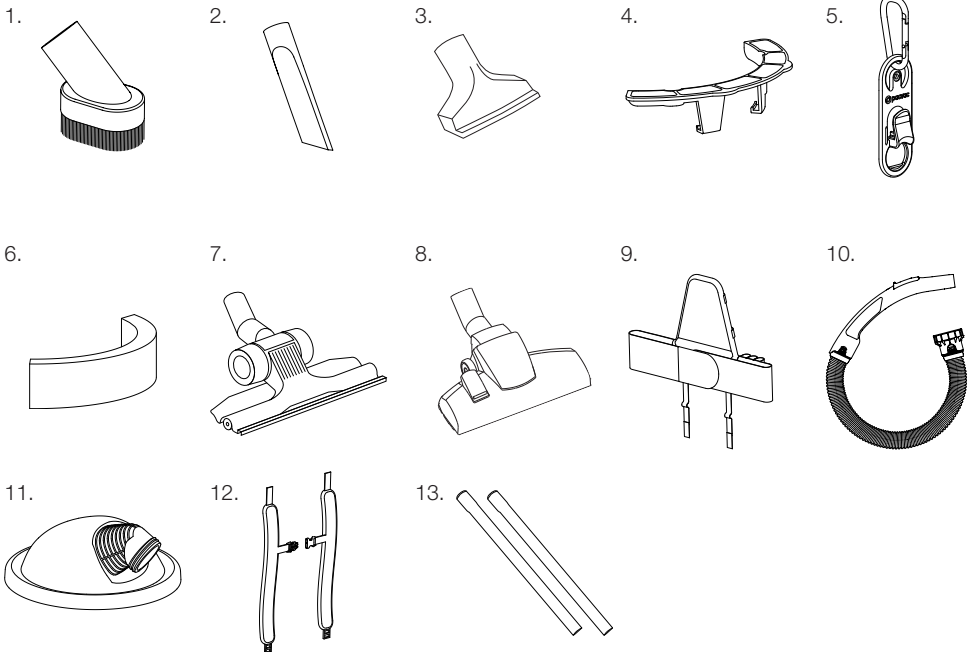

*Technical specifications, part numbers and parts designs are subject to change without notice.

Superpro 700 series

ENGLISH

Quote the following part numbers when ordering spare parts for the Superpro 700, Superpro trans 700, Superpro Wispa 700 and Superpro duo 700 only.

No.	Part Name	Part No.
14.	SMS Cone dust bag	DUB003
15.	Cone paper dust bag 10pk	DUB019
16.	Pre-motor HEPA rated filter (cone)	FIL001

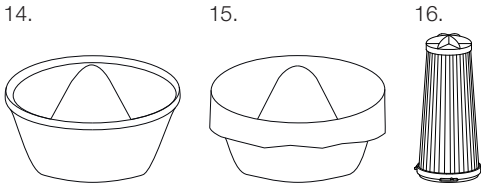

Quote the following part numbers when ordering spare parts for model Superpro micron 700 only.

No.	Part Name	Part No.
17.	Sealed paper dust bag 5pk	DUB004
18.	Reusable SMS dust bag (grey rim)	DUB007
19.	Pre-motor HEPA rated high grade filter	FIL003

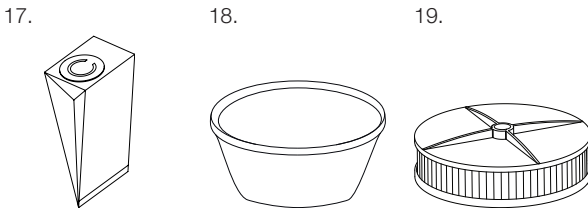

Quote the following part numbers when ordering spare parts for model Superpro 700, Superpro micron 700 and Superpro duo 700 only (not EU compatible).

No.	Part Name	Part No.
20.	C13 Short lead	SHL001

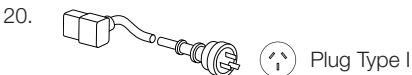

Quote the following part numbers when ordering spare parts for model Superpro wispa 700 only (not EU compatible).

No.	Part Name	Part No.
21.	C15 Horizontal right angle short lead	SHL004

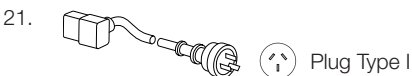

Quote these part numbers when ordering spare parts for all models (not EU compatible).

No.	Part Name	Part No.
22.	Extension lead 20m	EXL002

22.

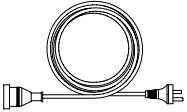

Quote the following part numbers when ordering spare parts for the EU model of Superpro 700 and EU model of Superpro micron 700 only.

No.	Part Name	Part No.
23.	18m Plug type E/F power cord	PWC006
24.	18m Plug type G power cord	PWC007

23.

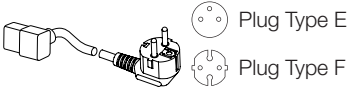

24.

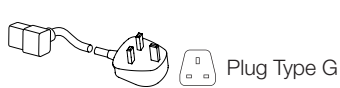

Optional Extras

Quote the following part numbers when ordering spare parts for all models.

No.	Part Name	Part No.
25.	Combination floor tool 270mm	FLT003
26.	Hard surface floor tool 300mm	FLT005
27.	Turbo head floor tool 280mm	FLT007
28.	Chrome handpiece	HAP003
29.	Telescopic wand	WND001

25.

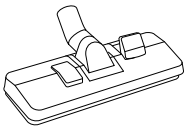

26.

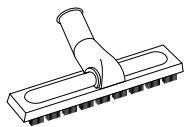

27.

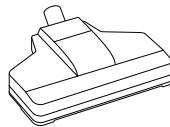

28.

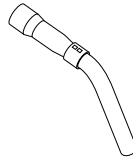

29.



EC Declaration of Conformity

We hereby declare that the machines described below comply with the relevant basic safety and health requirements of the EU Directives, both in its basic design and construction as well as in the version put into circulation by us. This declaration shall cease to be valid if the machine is modified without our prior approval.

Product: Dry vacuum cleaner

Type: 02PR700VB and 02MI700VB

Relevant EU Directives

2006/42/EC

2004/108/EC

2011/65/EU

2009/125/EC

Applied harmonised standards

EN 55014-1: 2006+A1

EN 55014-2: 1997+A1

EN 60335-1

EN 60335-2-69

EN 61000-3-2: 2006+A1

EN 61000-3-3: 2008

Applied national standards

-

Applied regulations

666/2013

The undersigned act on behalf and under the power of attorney of the company management.

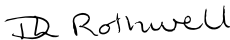

D. Rothwell

Executive Director

Authorised Documentation Representative D. Rothwell.

Pacvac Pty Ltd
7 Mackay Street
Kewdale WA 6105
AUSTRALIA
Phone: +61 8 9479 1444
Fax: +61 8 9479 5444

February 2020

Online Manual

Visit academy.pacvac.com or scan the QR code to access the online manual.

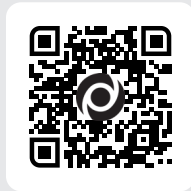

Revised: April 2020
MAN001-200407-superpro-700-series-manual

Pacvac Pty Ltd
ABN: 60 709 396 593
7 Mackay Street, Kewdale WA 6105
AUSTRALIA

 +61 8 9479 1444  support@pacvac.com  pacvac.com